



TIMESPACE

V400

INSTRUCTION MANUAL



DESIGNED AND MANUFACTURED
IN THE UK

V400 OPERATING SOFTWARE

THE V400 MANUAL IS AVAILABLE
ONLINE: www.tspace.co.uk

Contents

1. About This Manual.....	1
2. Quick Start Guide.....	2
2.1 System Overview	2
2.1.1 V400 Digital Video/Audio Recording System	3
2.1.2 Programming – X301 Reviewer.....	3
2.1.3 Help Screens.....	5
3. User Guide – V400 Menu System.....	6
3.1 Main Menu	8
3.1.1 Normal Recording	9
3.1.2 Timer Recording	11
3.1.3 Alarm Recording.....	13
3.1.4 IP Camera Recording.....	26
3.1.5 IP Camera View	29
3.1.6 SD Recording	30
3.1.7 Audio Recording.....	43
3.1.8 Recorded Files	46
3.1.9 Video Output.....	48
3.1.10 Main Video Switcher	49
3.1.11 Auxiliary Video Switcher.....	53
3.1.12 RTSP Switcher.....	54
3.2 Settings Menu.....	55
3.2.1 System Settings	55
3.2.2 Time And Date.....	56
3.2.3 Alarm Inputs/Outputs menu	58
3.2.4 Camera Settings	59

3.2.5	File System.....	62
3.2.6	System Info.....	67
3.2.7	System Security.....	68
3.2.8	Power Options.....	71
3.2.9	GSensor	79
3.2.10	Vehicle ID.....	82
3.2.11	Resource Allocation.....	83
3.2.12	Reset.....	86
3.3	External Equipment Menu.....	90
3.3.1	LAN1	91
3.3.2	LAN 2	93
3.3.3	GPS	94
3.3.4	GSM / Remote.....	96
3.3.5	PTZ Cameras.....	102
3.3.6	IBUS	104
3.3.7	Bridge Alert.....	105
3.3.8	CANLink	108
3.4	Advanced Menu.....	109
3.4.1	Health Page Display.....	111
3.4.2	Service Log.....	112
3.4.3	Load Software/Settings	114
3.4.4	Save Software/Settings	115
4.	System Information And Security	116
4.1	Language Selection.....	116
4.2	Video Standard – PAL and NTSC.....	116
4.3	File System.....	116
4.4	Video Compression	117

4.5	Audio	119
4.6	PC Access Precautions	120
4.7	PC Network Access	120
4.8	Watermark and Sequencing	122
4.8.1	Watermark	122
4.8.2	Sequencing	122
4.8.3	Watermark / Sequencing Report	123
5.	System Interfaces	124
5.1	GPS	124
5.2	Remote Operation (GSM / LAN / Wifi / 3G/4G) – Telnet / FTP	126
5.3	RS232 / TELNET External Control	127
5.4	USB Interface Kit	128
6.	Installation Guide	129
6.1	Safety	129
6.2	Environmental	129
6.2.1	Shock And Vibration	129
6.2.2	EMC	129
6.2.3	Recycling.....	129
6.3	Conformity	129
6.4	Warnings	130
6.5	V400 Connections	131
6.5.1	V400 Front Panel	131
6.5.2	Reviewer Connector	132
6.5.3	V400 Side Panel Interface /Connections.....	133
6.5.4	Main Out and Aux Out (Video Outputs).....	134
6.5.5	Camera connections.....	134
6.5.6	Molex Side Panel Connectors.....	134

6.5.7	Ethernet Connector	136
6.6	Installation Instructions.....	137
6.6.1	Proximity of other electrical equipment.....	137
6.6.2	Installation Check List (Example).....	138
6.6.3	Mechanical Data / Fixing Specification	139
6.6.4	Mounting Plates	141
6.6.5	Alarm I/O Wiring	142
6.6.6	Connecting an IP camera.....	143
6.6.7	Wiring a line level microphone	144
6.6.8	Installation Spare Parts List	145
7.	Service And Maintenance.....	146
7.1	Maintenance Regime	146
7.2	Service And Fail LED	146
7.3	Service Codes	147
8.	Software.....	149
8.1	V400 Software and Updates	149
8.1.1	Software upload via LANLink.....	149
8.1.2	Manual Software Upload	150
8.1.3	Software Download.....	150
8.2	PCLink Suite	152
8.3	LANLink.....	154
9.	Appendices.....	155
9.1	Appendix 1 – Manual revision history.....	155
9.2	Appendix 2 – V400 Data Sheet.....	156
9.3	Appendix 3 – Cartridge Range.....	157
9.4	Appendix 4 – Hard Disk Best Practice Guide.....	158
9.5	Appendix 5 – 37 Way D-Type connector / 9 pin serial port	159

9.6	Appendix 6 – Certificates of conformity and type approval	162
9.6.1	EC Declaration of Conformity.....	162
9.6.2	E11 R10 Approval (Electromagnetic compatibility)	163
9.6.3	E11 R118 Approval (Fire safety/burning behaviour of materials)	165
9.7	Appendix 7 - Splash Screen.....	168
9.8	Appendix 8 - Transport for London IBUS diagnostic interface	169
9.9	Appendix 9 - Tokens / Protocol.....	171
9.10	Appendix 10 - Health SMS Message Format	178

List of Figures

Figure 1 V400 Digital Video/Audio Recorder	2
Figure 2 X301 Reviewer connected to V400 DVR.	3
Figure 3 SD Card File Copy.....	36
Figure 4 Bridge Alert Control Unit.....	107
Figure 5 - Microphones	119
Figure 6 – PC network access ports.....	121
Figure 7 GPS Connection	124
Figure 8 V400 Front Panel	131
Figure 9 V400 Side Panel Interface/Connections.....	133
Figure 10 V400 Molex Side Panel Connectors	134
Figure 11 Ethernet Connector	136
Figure 12 V400 Measurement Data	139
Figure 13 V400 Front Panel Measurement Data.....	140
Figure 14 Mounting Plates	141
Figure 15 Alarm Input/Output Wiring.....	142
Figure 16 Wiring a line level microphone	144
Figure 17 37 Way D-Type connector/9 pin serial port.....	159

List of Abbreviations

Abbreviation	Meaning
AUX	Auxiliary
bps	Bits per second
CD	Compact Disk
CE	European Conformity
COM	Communication (port)
DHCP	Dynamic Host Configuration Protocol
DNS	Domain Name System
DVR	Digital video recorder
EEC	European Economic Community
EMC	Electro-magnetic compatibility
EMG	Emergency (EMG Splash Screen)
FAT	File Allocation Table
FMS	Fleet Management System
FTP	File Transfer Protocol
FPS	Frames Per Second
GB	Gigabytes
GMT	Greenwich Mean Time
GND	Ground
GPS	Global positioning System
GSM	Global System for Mobile Communications
HDD	Hard Disc Drive
HR	Hour
IP	Internet Protocol
IPS	Images per second
kHz	Kilohertz
KPH	Kilometres Per Hour
LAN	Local Area Network
LED	Light-Emitting Diode

MAC	Media Access Control
MB	Megabytes
MBR	Master Boot Record
MED	Medium
mics	Microphones
MIN	Minute
MPH	Miles Per Hour
OSD	On-screen display
PAL	Phase Alternating Line
PAR	Pre-Alarm Recording
PC	Personal Computer
PCB	Printed Circuit Board
PTZ	Pan Tilt Zoom (camera)
QUAL	Quality
RES	Resolution
RH	Relative Humidity
RMS	Root Mean Square
RTSP	Real Time Streaming Protocol
s	Second
SD	Secure Digital (card)
SDHC	Secure Digital High Capacity
SEC	Second
SMART	Self-Monitoring, Analysis and Reporting Technology
SMS	Short Message System
SSD	Solid State Disk
TB	Terabyte
TCP	Transmission Control Protocol
TFL	Transport for London
UK	United Kingdom
URL	Uniform Resource Locator (address of specific website or file on the internet)
USA	United States of America

USB	Universal Series Bus (cable system)
UTC	Co-ordinated Universal Time
V	Volts
VCA	Vehicle Certification Agency (UK)
VOR	Voice Operated Recording
Vrms	Root-mean-square Voltage
Wifi	Wireless local area network

1. About This Manual

This manual contains the information required for the installation and operation of the Timespace Technology V400 Digital Video Recorder (DVR).

This manual is divided into the following sections:

- [Quick Start Guide](#)
- [User Guide](#)
- [Installation Guide](#)
- [Service and Maintenance](#)
- [Software](#)
- [Appendices](#)

Where text in the body of the manual is shown in CAPITALS, this relates to one of the menu choices in the V400 menu system.

Within the [V400 User Guide](#) section of the Manual, links from menus to other menus or sub-menus are given as hyperlinks.

Detailed technical information can be found in the [Appendices](#), along with [certificates of conformity and type approval](#).

Recorded files can be viewed using PCLink, Timespace's proprietary reading and archiving software package. Detailed information on viewing the recorded files is found in the manual for [PCLink](#).

2. Quick Start Guide

2.1 System Overview



Figure 1 V400 Digital Video/Audio Recorder

2.1.1 V400 Digital Video/Audio Recording System

The V400 is a digital video/audio surveillance recorder for use in mobile applications. The V400 includes an integrated Power Supply (11-50V) and can provide power to two external monitors, GPS, Modem and cameras.

Recordings are made on a removable cartridge inserted in the V400. Optionally recordings can be written to a removable SD card.

Cartridges are available from Timespace in a range of storage size, hard disk drive (HDD) or Solid State drives (SSD). The list of available cartridges (at time of issue of this manual) can be found at [Appendix 3](#). A current list can be found on our website www.tspace.co.uk.

A guide to Best Practice in use of the hard disks is at [Appendix 4](#).

The recordings can be accessed by connecting the cartridge to a PC using the USB interface kit (Timespace part number T605) or cartridge station (Timespace part number T705). Timespace [PCLink](#) application is a proprietary reading and archiving software package used to review the recordings, and is supplied with both of these parts.

The [X301 Reviewer](#) is used to program the menu settings on the V400, check camera views and list the recorded files.

The V400's integral [GSensor](#) records the vehicle's movement for X, Y & Z axis.

2.1.2 Programming – X301 Reviewer

The V400 is configured using a tiered menu system. The menu system is accessed using the X301 Reviewer (pictured below).



Figure 2 X301 Reviewer connected to V400 DVR.

To enter Menu System press any of the four MENU arrow buttons.

To exit the Menu System or to move back up a level press the MENU EXIT button.

A keyboard is available to facilitate text input, eg for IP camera types, camera streams, camera text, vehicle ID. Use the Reviewer RIGHT navigation button to access the keyboard from the position where text is to be entered.

See the separate X301 Reviewer manual at <http://www.tspace.co.uk/pdf/timespace-reviewer-manual.pdf> for detailed information on the Reviewer's functions / controls and the full range of keyboard commands..

2.1.3 Help Screens

Each page on the menu system has an associated Help screen which describes the features on that page.

Pressing the HELP key on the [Reviewer](#) front panel will display the Help page. Use the UP/DOWN arrow keys to scroll through each help page.

The help pages included on the V400 are intended as a quick reference with more detailed descriptions contained in this V400 Manual.

3. User Guide – V400 Menu System

The V400 is configured using a tiered menu system. There are two top level menus through which all features and settings are configured.

The [MAIN MENU](#) relates to the recording functions, files and video output:



The [SETTINGS MENU](#) is where the V400 and any connected equipment are configured:



NB: Each menu, feature and setting is detailed in the following pages. Refer to the Table of [Contents](#) for reference to specific features, functions and settings.

A help system is included and can be displayed for each menu by pressing the HELP key on the [Reviewer](#).

Navigation of the menu system is by using the arrow keys on the [Reviewer](#).

All menu configuration items are changed instantly with the exception of the following which require a reboot:

- [VIDEO STANDARD](#) – switching between PAL/NTSC.
- [LANGUAGE FILE](#) – when loading a language file from the cartridge.

3.1 Main Menu



Recording modes in order of priority are:

- 1) [ALARM RECORDING](#)
- 2) [TIMER RECORDING](#)
- 3) [NORMAL RECORDING](#)

Only one mode is active at any one time. For example if ALARM RECORDING occurs during NORMAL RECORDING, ALARM RECORDING takes control but reverts back to NORMAL RECORDING once ALARM RECORDING has finished.

HINT: A MANUAL OVERRIDE feature exists. If the DVR is recording from a configured recording setting, eg TIMER RECORDING or ALARM RECORDING, and a user attempts to stop recording (by pressing the REC button on the Reviewer or on the V400 front panel), a warning message will be displayed. "MANUAL OVERRIDE ENABLED". To disable MANUAL OVERRIDE, press the record key again. To cancel the action, press the MENU EXIT key.

Audio recording can be turned on or off for all recording modes. This selection is found on the [AUDIO RECORDING](#) menu where other specific audio settings can be configured.

NB: Across the different recording modes, the V400 has some common settings, e.g. Images per Second (IPS). The IPS can be configured from 1 to 25 per camera. To save duplication, these options will only be documented in the first instance and subsequent features should be assumed to be the same unless explicitly stated.

3.1.1 Normal Recording

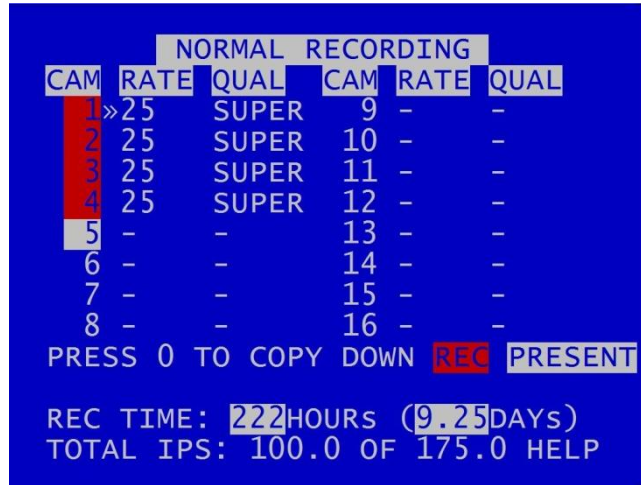

NORMAL RECORDING sets the normal recording configuration. Recording is activated by pressing the record button on the [front of the V400](#) or the [Reviewer](#). The V400 is also set to default record on power-up.

Connected cameras are identified by the relevant camera number being highlighted with either a white background (indicating camera present but not recording) or a red background (indicating camera present and recording). So in the above screenshot, cameras 1-5 are connected, but only cameras 1-4 are recording. Cameras 6-16 are not connected.

Images per second (**RATE**) and image quality (**QUAL**) can be set individually for each camera.

RATE can be set to; “-“ (OFF), 1, 1.5, 2, 3, 4, 5, 6, 7, 8, 9, 10, 12.5, 15, 20, 25 IPS (plus 30IPS for NTSC, see [VIDEO SETTINGS](#)).

QUAL can be set to; LOW, MEDIUM, HIGH, V.HIGH, VV.HIGH and SUPER.

The REC TIME is an indication of the number of Hours (also shown as number of whole and part days) that the V400 will record for based upon the current settings and entire installed cartridge capacity.

TOTAL IPS – provides details of current IPS allocation within NORMAL RECORDING, as well as the total IPS available for NORMAL RECORDING.

HELP – provides details of currently configured [RESOURCE ALLOCATION](#) across the various recording functions.

HINT: A “copy down” feature is available for configuring multiple camera settings. The settings for the currently selected camera will be copied down to all remaining cameras, subject to the global IPS limit. Press 0 to copy down.

By default all cameras are set to record in [NORMAL RECORD](#) mode, enabling quick deployment – just connect cameras and press the record button.

NB: the V400 is set to default record on power-up. Options to enable or disable recording at power-up are found in the [SETTINGS>ADVANCED](#) menu POWER STATE.

3.1.2 Timer Recording

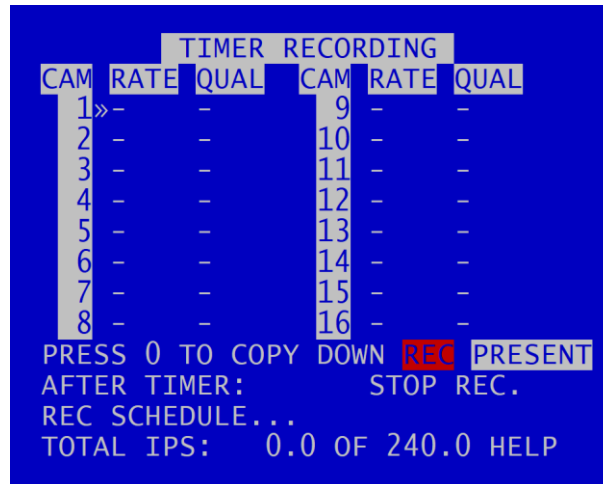

TIMER RECORDING sets daily on/off timers to provide timed recording. This menu sets the recording configuration and the times. During TIMER RECORDING the settings in this menu apply.

Images per second (**RATE**) and quality (**QUAL**) can be set individually for each camera in the same way as for [NORMAL RECORDING](#).

If AUDIO is required during TIMER RECORDING, this must be set up separately in the [AUDIO RECORDING](#) menu.

AFTER TIMER: At the end of a period of Timer recording the V400 can either STOP RECORDING or record in [NORMAL RECORDING](#) mode. The latter can be used if two recording styles are required based on time.

Enter the daily start and end times in the [RECORDING SCHEDULE](#) menu.

NB: ensure cameras have been configured for TIMER RECORDING or no footage will be recorded during times set in the RECORDING SCHEDULE.

The total number of configured images per second (IPS) is displayed along with the maximum.

TOTAL IPS – provides details of current IPS allocation within [TIMER RECORDING](#), as well as the total IPS available for TIMER RECORDING.

HELP – provides details of currently configured [RESOURCE ALLOCATION](#) across the various recording functions.

3.1.2.1 Recording Schedule



A SCHEDULE of TIMER RECORDING TIMES can be set. This can be used e.g. to record between a start date and end date. If both DAILY TIMES and PERIOD TIMES are selected, the V400 will record only in the period and also only in the daily times shown.

DAILY TIMER DISABLED – disables timer recording.

RECORD OUTSIDE DAILY TIMES – sets the unit to record at all times other than those specified in the daily times schedule.

RECORD BETWEEN DAILY TIMES – sets the unit to record between the daily times specified in the schedule.

A COPY DOWN features is available to copy the times set for Monday on to all other days of the week.

A period of TIMER RECORDING can be set e.g. to record between a start date and end date. Options for this are PERIOD TIMER DISABLED, RECORD INSIDE PERIOD, RECORD OUTSIDE PERIOD.

NB: By default the TIMER SCHEDULE is set to Mon-Fri 9-5 and all day Sat/Sun. Selecting RECORD OUTSIDE DAILY TIMES will give a quick outside office hours style recording.

HINT: Times are entered in the SCHEDULE using the digit keys on the front panel of the [Reviewer](#) for number [input](#).

3.1.3 Alarm Recording

ALARM RECORDING					
CAM	RATE	QUAL	CAM	RATE	QUAL
1»	25	VHIGH	9	-	-
2	25	VHIGH	10	-	-
3	-	-	11	-	-
4	-	-	12	-	-
5	-	-	13	-	-
6	-	-	14	-	-
7	-	-	15	-	-
8	-	-	16	-	-

PRESS 0 TO COPY DOWN **REC** PRESENT

PRE-ALARM RECORDING . . .

ALARM I/O MENU

TOTAL IPS: 50.0 OF 175.0 HELP

ALARM RECORDING is activated by the alarm inputs. This menu sets the alarm recording configuration.

Alarm recording can be triggered by setting the function of the alarm input to be ALARM REC. Inputs can also be used to trigger other functions and modes of recording.

Images per second (**RATE**) and quality (**QUAL**) can be set individually for each camera in the same way as for [NORMAL RECORDING](#).

[PRE-ALARM RECORDING](#) – configures the DVR to capture and retain a period of recording prior to an alarm input being triggered.

[ALARM I/O](#) menu – configures Alarm Recording and INPUT / OUTPUT options.

TOTAL IPS – provides details of current IPS allocation within ALARM RECORDING, as well as the total IPS available for ALARM RECORDING.

HELP – provides details of currently configured RESOURCE ALLOCATION across the various recording functions. A further [RESOURCE ALLOCATION MENU](#) provides detailed explanation of IPS allocation across the various recording features.

3.1.3.1 Pre-Alarm Recording

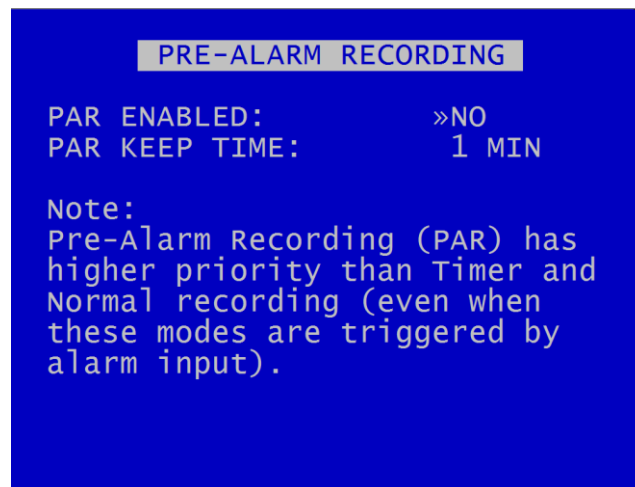

Pre-Alarm Recording (PAR), if enabled, configures the DVR to record for a set period of time prior to an alarm input being triggered, and for the DVR to keep the PAR files. This is useful in order to ensure that the lead-up to an alarm event is recorded. It avoids the need to have the DVR recording permanently, and it maximises the amount of available disk space, while ensuring that the recorded files for alarm event lead-up are kept.

PAR ENABLED – select YES or NO

PAR KEEP TIME – select the length recording from before the alarm input was triggered that you wish the DVR to keep. Available options are 1MIN, 2, 3, 4, 5, 10, 20, 30, 40, 50, 1HOUR, UNLIMITED.

The DVR will record all cameras specified for ALARM RECORDING for the duration specified in the PAR KEEP TIME setting. The DVR will be recording continuously, but will only keep the recordings for the specified time.

NB: Pre-Alarm Recording (PAR) has a higher priority than [TIMER](#) and [NORMAL RECORDING](#) (even when these modes are triggered by an alarm input).

3.1.3.2 Alarm Inputs/Outputs

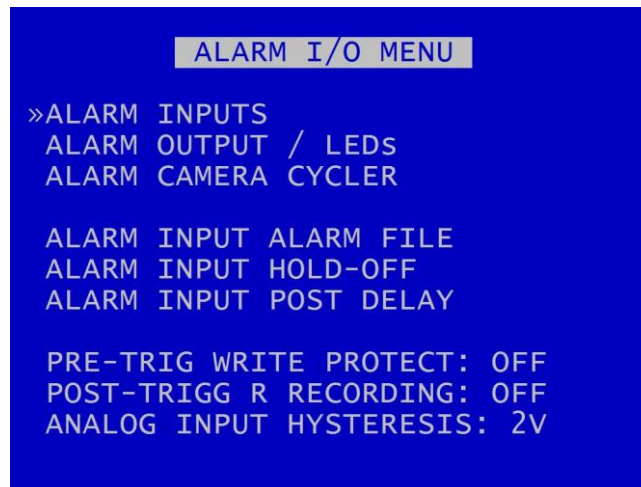

[ALARM INPUTS](#) menu – sets the active/inactive status of each alarm input and defines the function (action) of the V400 when the selected alarm is active.

[ALARM OUTPUTS / LEDS](#) menu – sets the conditions for the Alarm Outputs.

[ALARM CAMERA CYCLER](#) menu – configures the options for the V400 to automatically switch between cameras and the [Health Page](#).

[ALARM INPUT ALARM FILE](#) –provides an option for files to be marked as “ALARM” recordings.

[ALARM INPUT HOLD-OFF](#) – controls the number of seconds for which ALARM RECORDING is delayed after an alarm input has been triggered.

[ALARM INPUT POST DELAY](#) – controls the number of seconds for which the alarm state is held once the alarm input has changed state.

PRE-TRIG WRITE PROTECT – specifies the duration prior to the alarm recording for which files will be marked as write protected. This assumes that another mode of recording was already writing files to disk before the alarm was triggered. Pre-trigger values are: OFF, 1SEC, 2s, 5s, 10s, 20s, 30s, 40s, 50s, 1MIN, 2, 5, 10, 20, 30, 40, 50 MINS, 1HOUR, 2HOURS.

POST TRIGGER RECORDING – specifies the duration of recording after the alarm trigger. Once post trigger has elapsed, recording will stop or return to the previous recording mode. Post-trigger values are: OFF, 1SEC, 2s, 5s 10s, 20s, 30s, 40s, 50s, 1MIN, 2, 5, 10, 20, 30, 40, 50MINS, 1HR, 2HRS.

ANALOG INPUT HYSTERESIS – specifies the voltage value difference that must occur in order to change the alarm state e.g. if the trigger is set to 14V, when 14V is met the trigger will switch. In order to switch back, a change of 2V must occur i.e. 14-2 = 12V. Available values are 1V, 2, 3,4, 5, 6, 7 and 8V.

NB: The V400 has 10 alarm inputs and 4 outputs on the [side panel Molex connector](#).

3.1.3.3 Alarm Inputs

IN	ACTIVE	FUNCTION	CAMS
1	>>> 12V	NONE	
2	> 12V	NONE	
3	> 12V	NONE	
4	> 12V	NONE	
5	> 12V	NONE	
6	> 12V	NONE	
7	> 12V	NONE	
8	> 12V	NONE	
9	> 12V	NONE	
10	> 12V	NONE	

EMBED ALARM STATE MENU...
ALARM 1 IS INACTIVE @ (0.0V)

ALARM INPUTS menu sets the alarm inputs to be ACTIVE or INACTIVE. If an alarm input number is highlighted with a white background, this indicates its current state is active. No highlight indicates the state is inactive.

Use the left and right menu buttons on the [Reviewer](#) to set the active voltage. For a 24V vehicle system, use typically <12V or >12V. For a 12V vehicles system, use typically <6V or >6V.

NB: There is a priority order on the Alarm Inputs. The lower numbered Alarm Inputs take priority over the higher numbers. For example, if Alarm Input one is wired to the Reversing sensor, and is set to trigger Normal Recording when the Reversing sensor is activated, this alarm will take priority over any other alarm currently triggered.

FUNCTION lists the available [ALARM INPUT FUNCTIONS](#) for selection.

[EMBED ALARM STATE](#) menu configures options for adding text to recorded images.

ALARM 1 IS INACTIVE @ - Shows the current state of each of the alarm inputs. The corresponding number for each alarm input will be highlighted (white background) for ACTIVE and not highlighted for INACTIVE. To view the current state for each alarm input, use the arrow keys on the [Reviewer](#) to move up and down to each alarm number. The voltage is also shown.

ALARM INPUT FUNCTIONS

NONE	- No action
NORM REC	- Switches NORMAL RECORDING on
ALARM REC	- Switches ALARM RECORDING on.
SWITCHER	- Sets the Video Switcher (MAIN VIDEO OUT) to the selected camera.
TIMER REC	- Switches TIMER RECORDING on
SMS MSG	- Send one of the six user defined SMS text messages (GSM modem required).
HEALTH PAGE	- Displays the DVR Health Page .
PTZ PRESET	- Accesses the PTZ preset camera positions. 8 presets are available (setup using the PTZ menu) and a trigger can be used to invoke that position upon alarm State change.
SWITCHER 2	- Sets the Video Switcher2 (AUX VIDEO OUT) to the selected camera (V400-16 only).
IGNITION	- Linked to POWER OPTIONS menu to control how the V400 behaves on ignition
INDICATOR L etc	- Various vehicle alarm inputs - tags the particular alarm inputs as used for: INDICATOR L, INDICATOR R, BRAKE, SIDE LIGHTS, HEAD LIGHTS, FOG LIGHTS, HORN, BULL HORN, SIREN, BLUES, HAZARD WARN, DOOR, REVERSE, HANDBRAKE, ACCEL'TION
CAM CYCLER	- Automatically switches between cameras and the health page as configured in the ALARM CAMERA CYCLER menu from the ALARM I/O menu page.
MULTIVIEW	- Sets the main switcher to Multi Camera view (12/16 camera models)
AUDIO REC	- Must be used in conjunction with the AUDIO RECORDING menu, i.e. enabling AUDIO RECORDING FOR NORMAL, TIMER, ALARM or SD RECORDING .
BEEP TEST	- This is used for test purposes only and is not required by users.
POWER DOWN	- Instructs the DVR unit to power down when the alarm is triggered
EMG SPLASH	- Displays the DVR Splash Page .
DOOR 1-3	- tags the alarm inputs as used for doors
RAMP	- tags the alarm inputs as used for the ramp
PUSHBUTTON1 & 2	- tags the alarm inputs as used for additional buttons/triggers specified by the user
WIFI STATUS	- shows the WiFi/4G status for the vehicle. This allows LANLink to know if the external router is connected to LANLink via 4G or WiFi.
AUX IMAGE	- displays a JPEG image on the Aux monitor when the alarm is active. Further details are in AUX VIDEO SWITCHER .

Alarm inputs tagged as INDICATOR L/R or BRAKE will be displayed accordingly in future releases of PCLink when playing back recorded footage.

Each of the 10 alarm inputs can be set to turn on/off the selected FUNCTION. The FUNCTION defines the action of the V400 when the selected alarm input is active. The function is active for the duration of the alarm (plus post trigger time if selected - see [ALARM INPUTS/OUTPUTS MENU](#).):

If a recording mode is used as an alarm function, the settings are as per the settings in the relevant recording mode menu e.g. If NORM REC is selected, the settings in [NORMAL RECORDING](#) are used.

3.1.3.4 Embed Alarm State

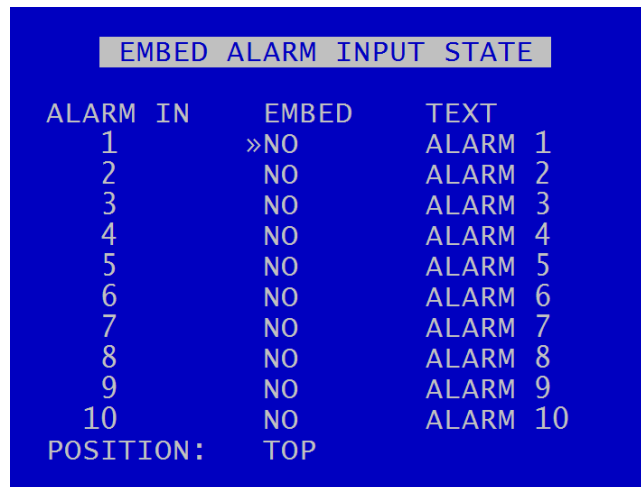

ALARM IN	EMBED	TEXT
1	»NO	ALARM 1
2	NO	ALARM 2
3	NO	ALARM 3
4	NO	ALARM 4
5	NO	ALARM 5
6	NO	ALARM 6
7	NO	ALARM 7
8	NO	ALARM 8
9	NO	ALARM 9
10	NO	ALARM 10
POSITION:	TOP	

The EMBED ALARM INPUT STATE menu configures options for adding text to recorded images.

8 user defined characters can be entered per input and positioned either top or bottom of the image. The text will display on the footage for the duration of the alarm, plus any post alarm duration.

POSITION – select TOP or BOTTOM

Text is entered using the Text and Number Input keys on the [Reviewer](#).

The text will be embedded on all camera views simultaneously and will appear on all selected cameras during playback in PCLink.

3.1.3.5 Alarm Outputs



ALARM OUTPUT menu sets the conditions for the Alarm outputs. This determines whether the V400 alarm output goes closed (pull to GND) or open circuit when any of the set conditions are met.

ALARM OUTPUT CLOSED/OPEN **WHEN...**

- TEST OPEN/CLOSED - Sets the input to OPEN/CLOSED for testing purposes.
- ALARM OCCURRED - An ALARM event has occurred.
- RECORD LED - The front panel record LED is active.
- DISK LED - The front panel disk LED is active.
- SD RECORDING - SD recording is occurring.
- FAIL LED - The front panel fail LED is active.
- SERVICE LED - The front panel service LED is active.
- FRONT LEDS - Any of the front panel LEDs are active.
- CAM DISCONNECTED - Any camera is disconnected.
- GSENSOR TRIGGER - Any of the GSensor configured thresholds are reached / exceeded.
- LAN ACTIVE - Files are being transferred via the LAN interface.
- HD WP % - A percentage of the disk contains Write Protected files: 25, 50, 60, 70, 80, 90 and 99%.
- HD FULL % - A percentage of the disk if full; 25, 50, 60, 70, 80, 90 and 99%.
- AUDIO VOR - Voice Operated Recording. If the detected level of audio input reaches a certain percentage (25%, 50%, 75%) the alarm output can be triggered. If using this trigger as an alarm *input*, a wire link will need to be in place on the V400 rear panel to take the alarm out to an alarm input (see [Figure 10 Molex side connectors](#) for wiring pinout).
- ON WITH IGNITION - Ignition is active.
- GPS SPEED ALARM - The vehicle speed exceeds the limit selected in the GPS menu (SETTINGS MENU > EXTERNAL EQUIPMENT > [GPS > SPEED ALARM](#)).
- CURRENT STATE - Indicates when each alarm output is CLOSED/OPEN (CLOSED showing alarm terminals connected; OPEN showing alarm terminals not connected).

3.1.3.6 Alarm Camera Cycler

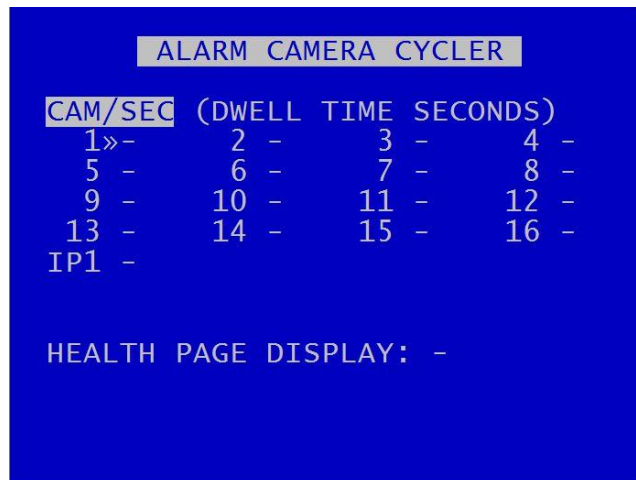

The ALARM CAMERA CYCLER menu configures the options for the V400 to automatically switch between cameras and the [Health Page](#). When the Cam Cycler is activated, the DVR will display each selected camera, and/or HEALTH PAGE, on the main monitor ([MAIN VIDEO SWITCHER](#)) for a specified amount of time. This enables the user to confirm if all selected cameras are working as required.

Set the number of seconds for each camera required to show in the camera cycle. Available values are 1, 2, 3, 4, 5, 10, 20, 30 seconds.

HEALTH PAGE DISPLAY – sets the number of seconds for which the camera cycler shows the [Health Page](#) in the Camera Cycler cycle. Available values are 1 second, 2s, 3s, 4s, 5s, 10s, 20s and 30seconds.

3.1.3.7 Alarm Input Alarm File

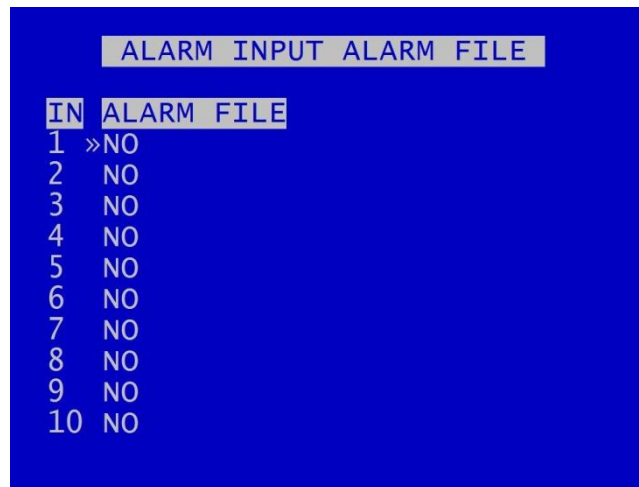

The Alarm Input Alarm File feature provides an option for files to be marked as alarm event files if recording in any recording mode, ie not just in [ALARM RECORDING](#).

If any of the above numbered ALARM FILES are set to YES, then the current recording file will be marked as an ALARM recording if that numbered alarm is active.

NB: The currently configured recording mode (i.e. NORMAL, TIMER, etc) will not change. The alarm event will simply be marked as an alarm event file. This will make the alarm event easier to identify when finding files on the HDD or viewing in [PCLink](#).

An example scenario where ALARM INPUT ALARM FILE may be useful:

A fire engine has a DVR which is configured for NORMAL RECORDING (Note: no ALARM INPUT FUNCTIONS have been configured for NORMAL or ALARM RECORDING).

[ALARM INPUT 3](#) has been configured for SIREN, and ALARM INPUT ALARM FILE 3 has been set to YES.

When the SIREN becomes active, this triggers ALARM 3. Note: the recording mode does not change, and NORMAL RECORDING continues as per prior to the alarm trigger.

On file close, the recording file is marked as an alarm event file (A). All subsequent files created when the alarm is active are marked as ALARM files at file creation.

3.1.3.8 Alarm Input Hold-Off

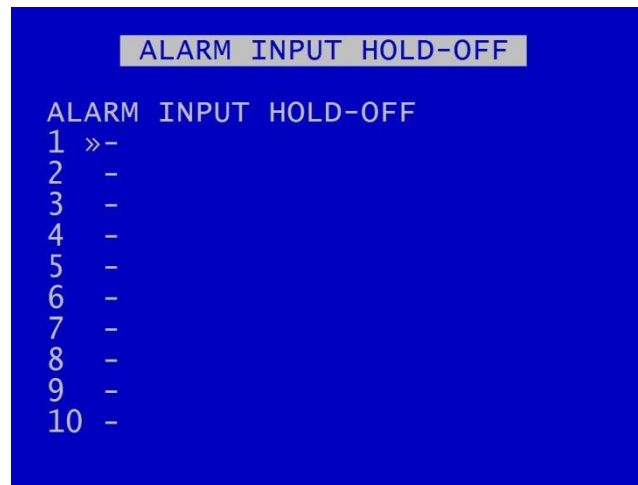

The ALARM INPUT HOLD-OFF controls the number of seconds for which reporting of an active alarm state is delayed after an alarm has triggered to the active state.

For each Alarm Input, select a hold off value. Options are 1SEC, 2, 3, 5, 10, 15, 20, 30, 45, 60 SECS.

This may be useful in scenarios where accidental or very short-term action would otherwise trigger an alarm. In these cases, the user may not wish the alarm to be triggered, or the alarm event to be marked in the [RECORDED FILES](#).

Examples of scenarios where ALARM INPUT HOLD-OFF may be useful:

1. A camera is recording activity at the rear door of a retail premises. The door is alarmed and the DVR configured to begin alarm recording if the door is open. The user may decide to implement an ALARM HOLD-OFF period so that ALARM RECORDING does not begin until the door has been open for eg 3 seconds – thus avoiding recording whenever a staff member opens the door accidentally, but ensuring that recording takes place whenever the door is held open for a delivery.
2. A waste disposal truck has a DVR which is configured to trigger ALARM RECORDING whenever reverse gear is engaged. This is to ensure that managers can view all reversing footage and check that drivers are complying with the reversing speed limit. The user may choose to set an ALARM INPUT HOLD-OFF for eg 2 seconds in order to avoid triggering ALARM RECORDING when the driver accidentally engages reverse gear without actually moving the vehicle.

3.1.3.9 Alarm Input Post Delay

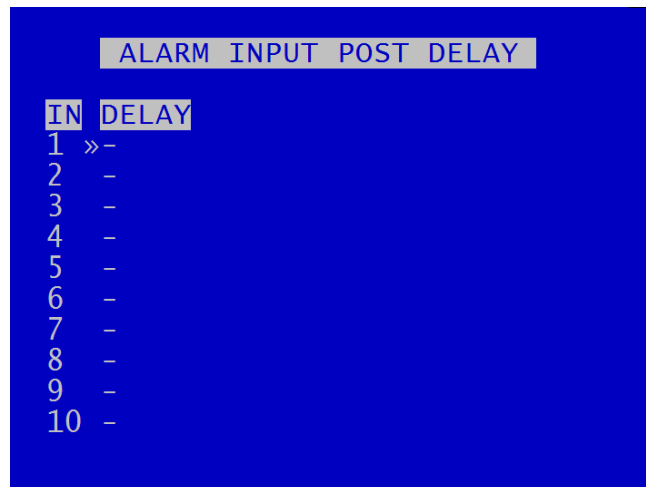

ALARM INPUT POST DELAY	
IN	DELAY
1	»-
2	-
3	-
4	-
5	-
6	-
7	-
8	-
9	-
10	-

ALARM INPUT POST DELAY menu controls the number of seconds for which the alarm state is held once the alarm input has changed state.

Available values are 0.5SEC, 1, 2, 3, 4, 5, 10, 30SECS, 1MIN, 5MINS, 10, 15, 20MINS.

3.1.4 IP Camera Recording

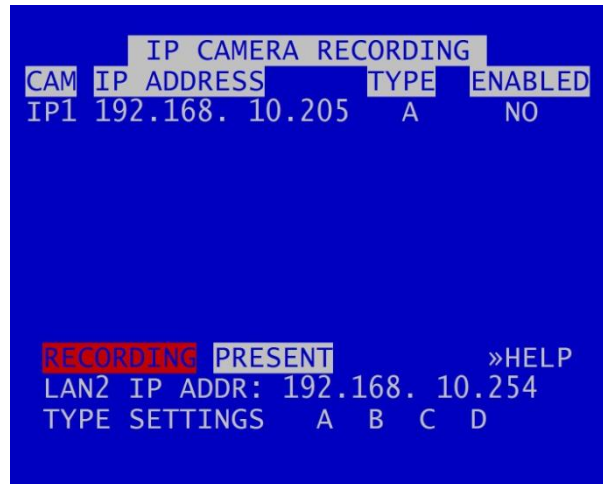

The IP CAMERAS menu configures settings for the single IP camera input supported by the V400 unit.

IP ADDRESS – must be set to the IP address of the IP camera.

TYPE SETTINGS – identifies which Type (A, B, C, D) the IP camera is allocated to. Types are used to configure the username, password and camera stream URL in order for the V400 to receive data from the IP camera. The camera details for each Type are input in the [TYPE SETTINGS](#) menu page.

ENABLED – select YES/NO. When set to YES, this allows the IP camera stream to be recorded. IP cameras can be recorded stand-alone even if not analogue (SD) cameras are configured.

LAN2 IP ADDR – the IP camera’s address and LAN2 IP address must be configured for the same network.

NB: the local IP address and [TYPE SETTINGS](#) cannot be changed while recording is in progress – an “IP CAMERA WARNING” will be displayed. Stop recording and amend the IP address and settings as required before recommencing recording.

To test connectivity of the IP Camera, configure the unit so it is not recording, configure the IP camera and set ENABLED to YES. If the IP Camera is present, the CAM number will be highlighted with a white background.

If the IP Camera is not present, or there is a fault, the number will remain unhighlighted.

To check if the IP Camera is being recorded, set ENABLED to YES, begin recording, and the CAM number will be highlighted with a red background.

NB: Timespace recommends that IP cameras are configured for a constant rather than variable rate. This can be done within the IP camera’s own settings.

IP Camera live footage can be viewed using the Reviewer or on the [VIDEO OUTPUT](#).

NB: the IP camera stream will only be recorded as long as the unit is recording in another mode i.e. [NORMAL RECORDING](#), [TIMER RECORDING](#) etc.

NB: the connection of one IP camera requires 100IPS, thus reducing the available IPS for other recording functions.

For further information on IPS allocation, see [RESOURCE ALLOCATION](#) and [RESOURCE ALLOCATION MENU](#).

3.1.4.1 Type Settings

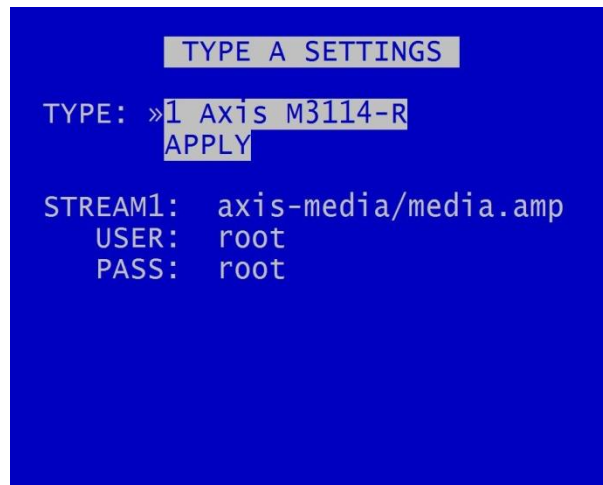

The TYPE SETTINGS menus define the network URLs which allow the unit to open up a network stream for recording the IP Camera.

TYPE – states the type of camera set to the specified TYPE SETTING. Use the right menu button to select from the available options.

STREAM – the stream will need to be discovered using Onvif device manager or equivalent third party application or IP camera documentation.

USER – the username

PASS – the password

Details of USER name and PASSWORD should be found in the support documentation for the individual cameras purchased by users.

On default each Group path has been set to a particular camera type which has been tested by Timespace.

NB: Available camera options will be updated by Timespace and included in subsequent software releases. Users can also obtain an current list of cameras by contacting Timespace at support@tspace.co.uk. The update will be provided as a TCONFIG file which can be uploaded using the [LOAD SOFTWARE/SETTINGS](#) option in the [ADVANCED](#) MENU.

3.1.5 IP Camera View

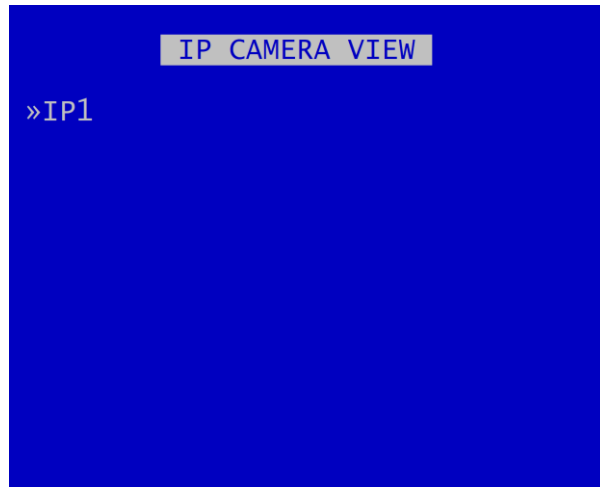

The IP camera live view on the Reviewer is accessed via this menu.

NB: this menu page is only visible if IP LOCAL Live View has been enabled (set to YES) in the [VIDEO OUTPUT](#) menu.

3.1.6 SD Recording

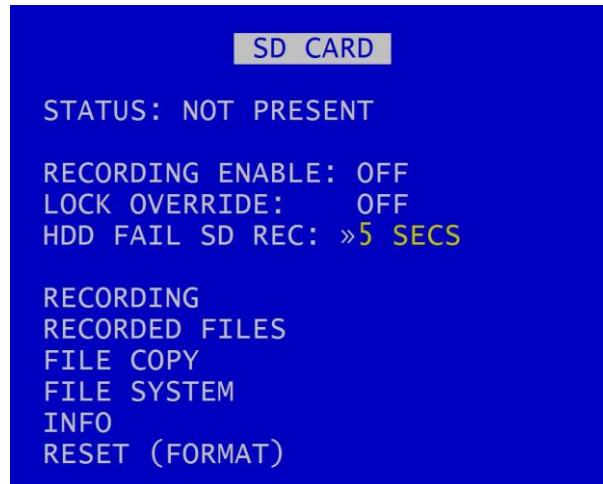

The V400 supports a single SD card for two functions;

RECORDING - The V400 can be configured to record up to 25 IPS to the SD card in addition to the primary recording to the cartridge. All additional data for example Audio and GPS are also included within the SD recorded files.

NB: the 25IPS limit does not apply when in SD Card HD Mirror Mode. See [HD Mirror Mode](#) section for further details.

FILE COPY - Files that are recorded on the V400 cartridge can be selected and copied to the SD card for review on a PC.

The SD Card menu shows the current Status of the SD card i.e. PRESENT, NOT PRESENT, LOCKED or RECORDING TO SD.

RECORDING ENABLE lists the available modes of recording for the SD card.

- OFF – SD recording is OFF, no SD recording
- ON – SD recording onto SD card all the time.
- IF NORMAL REC – SD recording only occurs if the V400 is recording in Normal mode.
- IF TIMER REC – SD recording only occurs if the V400 is recording in Timer mode.
- IF ALARM REC – SD recording only occurs if the V400 is recording in Alarm mode.
- HD MIRROR – SD card is recording in mirror mode – see [SD Card HD Mirror mode](#).

LOCK OVERRIDE options OFF or ON can be used to override the physical lock status of the SD card. For example if an SD card is inserted with the lock enabled, this usually prevents any data being written, however the V400 can override this.

HDD FAIL SD REC sets the number of seconds that the V400 will continue to record to the SD card when a FAIL to write to the hard disk drive (HDD) is detected. Available values are 5SECS, 10, 20, 30SECS, 1MIN, 2, 3, 4 5MINS. After the configured time has elapsed, the V400 will reboot in an attempt to continue writing to the HDD after boot up. If the HDD fails due to a crash the SD will carry on recording for the selected period so that the crash events are stored.

[RECORDING](#) menu configures the SD card recording setup, ie allows the user to select number of cameras, RATE and QUAL.

[RECORDED FILES](#) menu displays a list of the files on the SD card.

[FILE COPY](#) menu is used when copying files from the V400 cartridge to the SD card.

[FILE SYSTEM](#) menu configures options for recording on the SD card, including file password and encryption options.

[INFO](#) page includes details such as; Size, % used, SD serial number etc.

[RESET](#) gives options for deleting files on the SD card and to securely wipe the data on the SD card so that it cannot be recovered.

3.1.6.1 SD Card – HD Mirror mode



The HD Mirror mode mirrors the data that is being recorded to the hard drive as configured in [NORMAL RECORDING](#). This mirrored data is then recorded onto the SD card. In this mode, the normal SD card 25IPS recording limit does not apply. In addition, HD Mirror Mode can include the recording of the IP Camera to the SD card.

Selection of HD Mirror Mode has no impact on the DVR's performance.

NB: if HD MIRROR mode is selected, the user will not be able to select cameras, rates or quality in the SD RECORDING menu – these settings will mirror those already configured in NORMAL RECORDING – and the following advisory screen will be shown:



The REC TIME shown on this screen will be the time for which the DVR can record to SD card in HD Mirror mode. This time is calculated based on the number of cameras, RATE and QUAL set in NORMAL RECORDING and is dependent on the capacity of the installed SD card (currently supported up to 2TB).

3.1.6.2 SD Card Recording

SD CARD RECORDING					
CAM	RATE	QUAL	CAM	RATE	QUAL
1	10	»MED	9	-	-
2	10	MED	10	-	-
3	-	-	11	-	-
4	-	-	12	-	-
5	-	-	13	-	-
6	-	-	14	-	-
7	-	-	15	-	-
8	-	-	16	-	-

PRESS 0 TO COPY DOWN **REC** **PRESENT**

REC TIME: **35**HOURS (**1.45**DAYS)
TOTAL IPS: 20.0 OF 25.0 HELP

SD CARD RECORDING menu - The V400 can be configured to record up to 25 images per second (IPS) to the SD card in addition to the primary images per second being recorded to the cartridge. All additional data e.g. audio and GPS are also included within the SD recorded files.

Images per second and quality can be set independently, per channel, from the V400's primary mode of recording e.g. if the V400 is Normal Recording with a QUAL of SUPER, the SD recording files can be set to MED.

For details of quality options see the section on [NORMAL RECORDING](#).

TOTAL IPS – provides details of current IPS allocation within SD CARD RECORDING, as well as the total IPS available for SD CARD RECORDING.

HELP – provides details of currently configured [RESOURCE ALLOCATION](#) across the various recording functions.

3.1.6.3 SD Card Recorded Files

SD CARD RECORDED FILES				
FIRST	/	LAST	PAGE	
PAGE	1	OF	5	
W__GA	FILTER	OFF	SIZE	MB
_____	11:32:28	26/07/16	31.7	
_____	11:32:24	26/07/16	3.3	
_____	11:30:38	26/07/16	28.9	
W_____	11:28:36	26/07/16	3.1	
W_____	11:50:00	21/06/16	296.1	
_____	11:40:00	21/06/16	387.9	
_____	11:30:00	21/06/16	387.9	
_____	11:20:00	21/06/16	387.8	
>>W_____	11:10:00	21/06/16	387.9	
_____	11:00:00	21/06/16	387.8	

The SD CARD RECORDED FILES menu lists the files recorded on the SD card.

The files cannot be played back on the V400, and must be viewed through [PCLink](#). Navigation of the file list pages are via the left/right arrow menu keys when PAGE or FIRST/LAST page is highlighted.

HINT: Files can be write-protected by scrolling down to the file and pressing the left arrow key, a W should appear next to the file. Pressing left again will remove the write-protect.

3.1.6.4 SD Card File Copy



SD CARD FILE COPY is used to copy recorded files from the V400 cartridge to the SD card. A link to the main cartridge HDD files give quick access to see what is on the cartridge. Some SD statistics are given to aid in the select process e.g. size and capacity used.

Use [HDD RECORDED FILES](#) to view the files on the hard disk.

COPY HDD FILES TO SD CARD by entering the start/end date & time of the period you wish to copy and then move the cursor down to select COPY FILES.

If there is enough free capacity on the SD card, the copy will begin. Progress of the copy will be displayed as a percentage and incremental file count as each file is copied.

WARNING: If other Menu buttons on the [Reviewer](#) are pressed during the FILE COPY, the action will be aborted. It is necessary to allow the FILE COPY to finish before attempting any other Menu/programming options.

A message will be displayed on the SD CARD FILE COPY menu screen when the FILE COPY is complete.

If the period requested spans multiple files, all files are copied to the SD card for that period. Files are not cut / clipped. In the following example, all four files would be copied, even though files 1 & 4 only include a portion of the period requested;

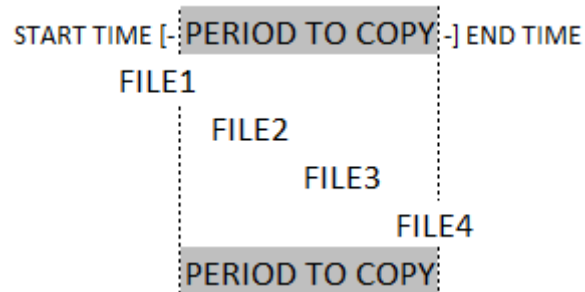
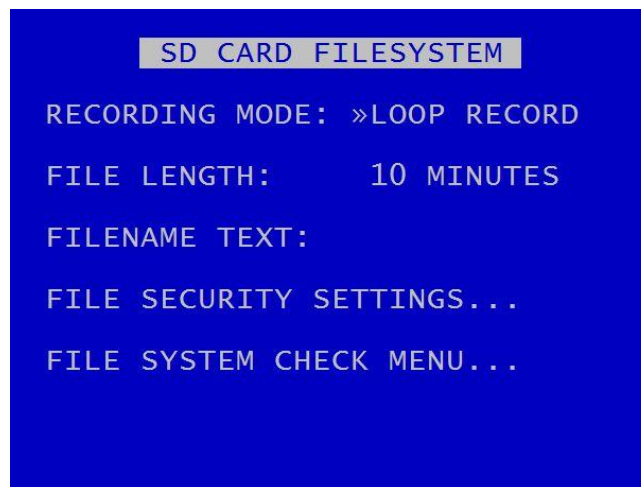

Figure 3 SD Card File Copy

3.1.6.5 SD Card File System



SD CARD FILE SYSTEM menu configures options for recording on the SD card.

RECORDING MODE can be set to LOOP RECORD (oldest files will be overwritten first when the hard disk cartridge is full); or SINGLE PASS recording (recording will stop when the hard disk cartridge is full).

FILE LENGTH controls how often a new file is created. A new file is created each time recording starts. The file will be named with the date/time when the recording started. The next file will be started as per the file length settings or when next time boundary is met.

File length options are 1MINUTE, 5MINUTES, 10MINUTES, 1HOUR. For further details refer to [FILE SYSTEM](#) menu for the main hard disk cartridge.

FILENAME TEXT - prefixes the recording files with user-defined characters. Characters can be entered using the Text and Number Input keys on the [Reviewer](#).

[FILE SECURITY SETTINGS](#) – configures options for file password and encryption.

[FILE SYSTEM CHECK](#) MENU configures system checking and the creation of system logs for SD CARD RECORDING.

3.1.6.6 SD Card File System Check

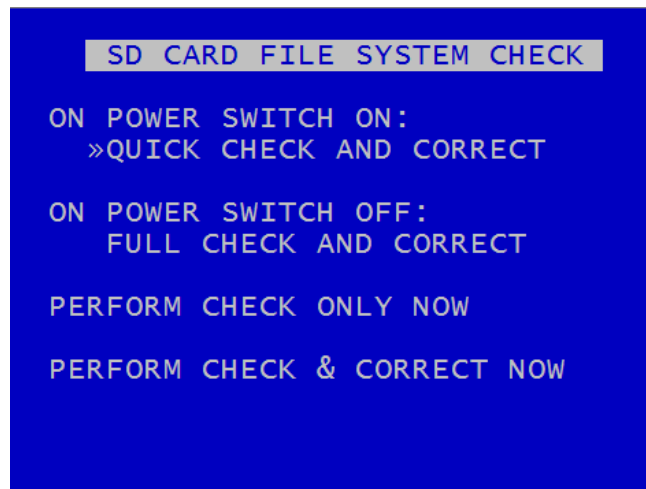

SD CARD FILE SYSTEM CHECK menu configures whether the file system is checked and/or corrected at power-up and whether a system log is created.

ON POWER SWITCH ON – options are NO CHECK, QUICK CHECK AND CORRECT, FULL CHECK AND CORRECT.

ON POWER SWITCH OFF – NO CHECK, QUICK CHECK AND CORRECT, FULL CHECK AND CORRECT.

PERFORM CHECK ONLY NOW – will check the files and file system and report any errors but will not attempt to fix anything.

PERFORM CHECK & CORRECT NOW – will perform a file and file system check and fix any errors that are found. It also rewrites the FAT and BOOT sectors.

NB: No files/data are deleted during the CHECK & CORRECT function.

3.1.6.7 SD Card Info

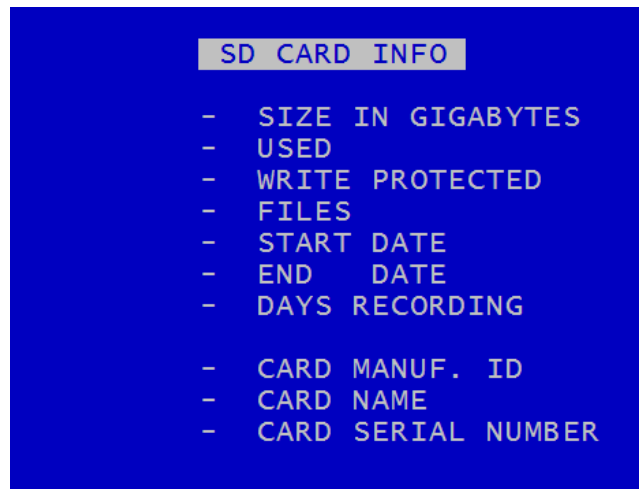

SD CARD INFO menu provides information about the use of the SD card:

- Size in Gigabytes
- percentage of the SD card used
- Write protection status
- Files
- Start date
- End date
- Days Recording
- Card Manufacturer ID
- Card Name
- Card Serial Number

3.1.6.8 SD Card Reset

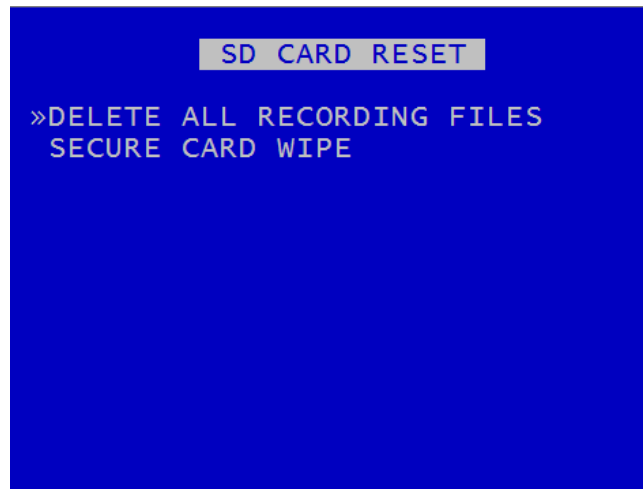

SD CARD RESET gives 2 options for deleting files:

[DELETE ALL RECORDING FILES](#)

[SECURE CARD WIPE](#)

3.1.6.9 Deleting SD Recording Files

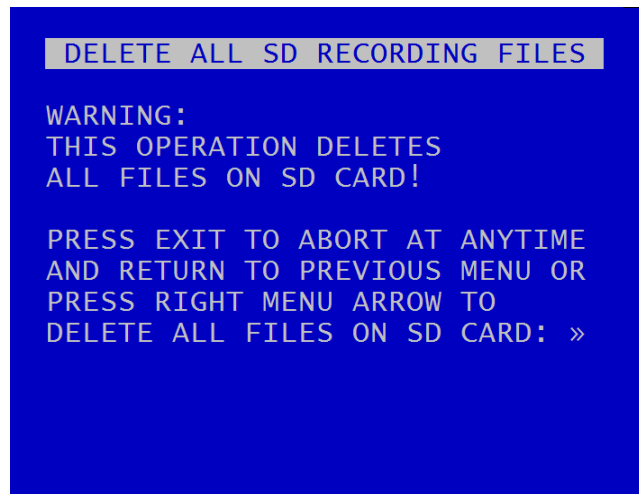

DELETE ALL SD RECORDING FILES will remove all recordings from the SD card including write-protected files. Only do this if you want to completely remove all recordings – there is NO undo option. Press the right menu button on the [Reviewer](#) to go to a warning screening, press right again to carry out this action. Pressing Menu Exit will abort this procedure.

WARNING: THERE IS NO “UNDO” OPTION. SELECTING “DELETE ALL FILES ON SD CARD” WILL COMPLETELY REMOVE ALL RECORDINGS ON THE SD CARD.

3.1.6.10 Secure SD Card Wipe

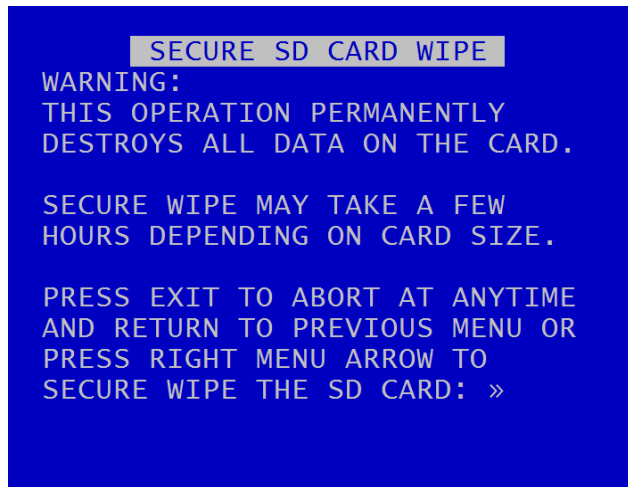

SECURE SD CARD WIPE will permanently delete all recording files on the SD card. This should only be used if files need to be completely destroyed. NO files will be able to be recovered. A final warning message will appear before this function is carried out. Pressing Menu Exit on the [Reviewer](#) will abort.

WARNING: THERE IS NO “UNDO” OPTION. SELECTING “SECURE WIPE THE SD CARD” WILL COMPLETELY REMOVE ALL RECORDINGS ON THE SD CARD.

3.1.7 Audio Recording

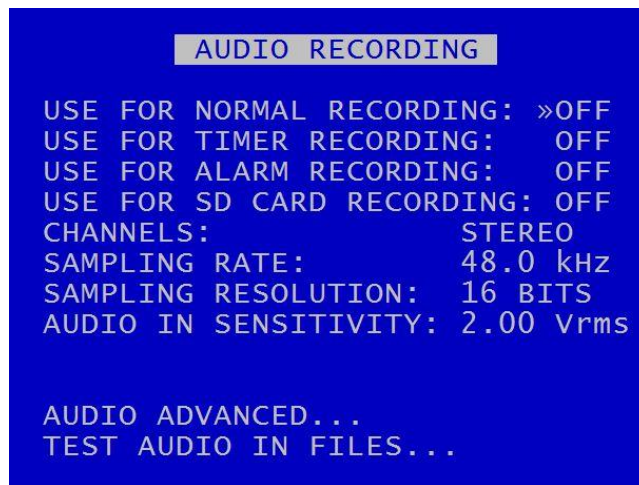

AUDIO RECORDING menu allows configuration of the audio recording parameters. Audio can be enabled or disabled (ON / OFF) for the following recording types; [NORMAL](#), [TIMER](#), [ALARM](#) and [SD CARD](#).

The V400 has a built in preamplifier so mics can be connected directly to the [side panel](#) interface.

CHANNELS can be set to STEREO, MONO-R, MONO-L.

SAMPLING RATE can be set to 8kHz, 16, 32, 44.1 or 48kHz.

SAMPLING RESOLUTION is set to 16 BITS, giving CD-quality audio recording.

AUDIO IN SENSITIVITY – The V400 is configurable so that the line-level input range can be set. Selectable values are 0.12, 0.25, 0.5, 1.00 and 2.0Vrms (sensitivity).

Individual audio channels can be played back using [PCLink](#) PC software.

[AUDIO ADVANCED](#) – configures further settings for AUDIO RECORDING.

TEST AUDIO IN FILES – allows the user to play files on the Reviewer with *just* the audio to test the audio function, eg when configuring and testing microphones. No video will play on the Reviewer during the audio test. To listen to recorded audio along with the associated recorded footage, files must be played back in [PCLink](#).

3.1.7.1 Audio Advanced Menu

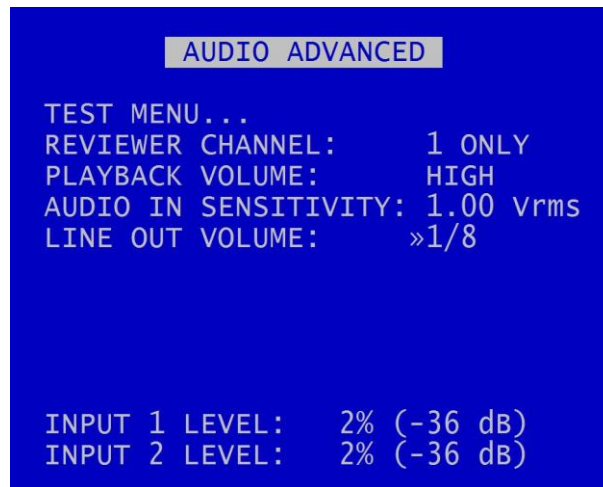

AUDIO ADVANCED menu gives further options for configuring Audio features.

TEST MENU – provides options for testing the Audio function.

REVIEWER CHANNEL – used to switch the live/playback output channel between 1, 2 or 1 and 2.

PLAYBACK VOLUME – Playback volume of the Reviewer’s built-in speaker can be adjusted between MUTE, LOW, MEDIUM, HIGH, FULL.

AUDIO IN SENSITIVITY – can be set from 0.12 - 2.0Vrms.

LINE OUT VOLUME – provides options to set the volume of Audio Line Out, eg when used for [BRIDGE ALERT](#). Selectable options are ½, ¼, 1/8, 1/16, 1/32, FULL. PLAYBACK VOLUME and LINE OUT VOLUME can be used together to fine-tune the volume.

INPUT LEVEL - when recording, input levels will be shown as NOT RECORDING or as a percentage so the V400 can be setup to avoid distortion. The sensitivity configuration will be dependent on the environment of the installation.

3.1.7.2 Audio Test Menu

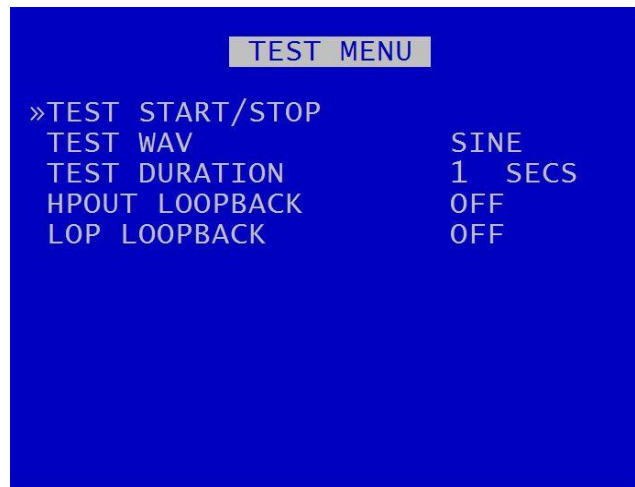

TEST START/STOP – will commence or stop the audio test.

TEST WAV – for Timespace test purposes only.

TEST DURATION – selectable from 1-60 Seconds or perpetual.

HPOUT LOOPBACK – can be selected to OFF/ON. This provides high power output for listening to live audio being recorded using the speaker on the [Reviewer](#).

LOP LOOPBACK – can be selected to OFF/ON. This provides high power output for listening to live audio using the V400's [interface panel](#) audio output socket.

3.1.8 Recorded Files

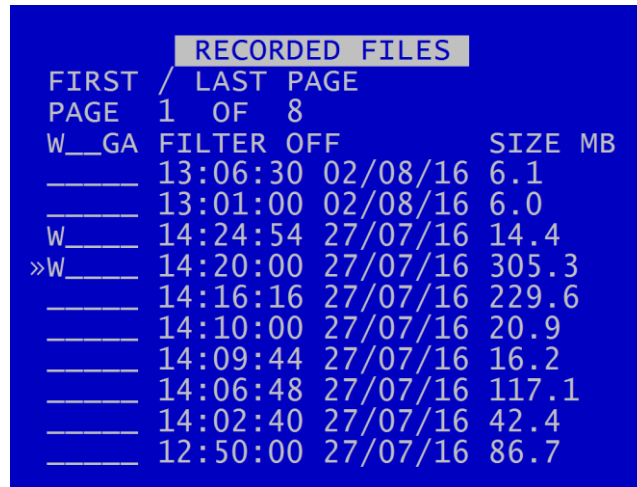

RECORDED FILES menu lists the recorded files on the HDD and allows the user to select a file to play or to change the write-protect state of a file.

Files are shown in chronological order, most recent file first. Files are displayed by;

HH:MM:SS DD/MM/YY SIZE MB

File status indicators shown to the left of the file include;

- W** - Write protected
- A** - Alarm
- P** - Alarm PAR
- K** -Alarm PAR Keep
- G** - GSensor

A file may have multiple statuses. For example a write protected alarm file could have; A W _ _ _

A file with a W status will not be overwritten on [Loop Recording](#).

HINT: The W status can be added or removed by pressing the Left Menu Navigation key when the cursor is next to the recorded file.

Navigation is using the Menu Navigation keys on the [Reviewer](#) as follows:

- FIRST / LAST PAGE – Left key = go to last page; Right key = go to first page
- PAGE – Left key = go to next page; Right key = go to previous page; Up/Down keys = move cursor to a file

The files can be filtered into the following groups:

- Write protect
- GSensor Alarm
- Alarm Recording

Each file type can be filtered by toggling through the headers. When one of the letters is highlighted, files with that attribute will be displayed in the file menu.

HINT: To highlight a file status indicator, use the right arrow key to scroll through W, G, A. The selected letter will have a white background, and a message “FILTER ON” will be displayed.

Continuing to scroll with the right arrow button will take the selection back to “FILTER OFF”.

3.1.9 Video Output

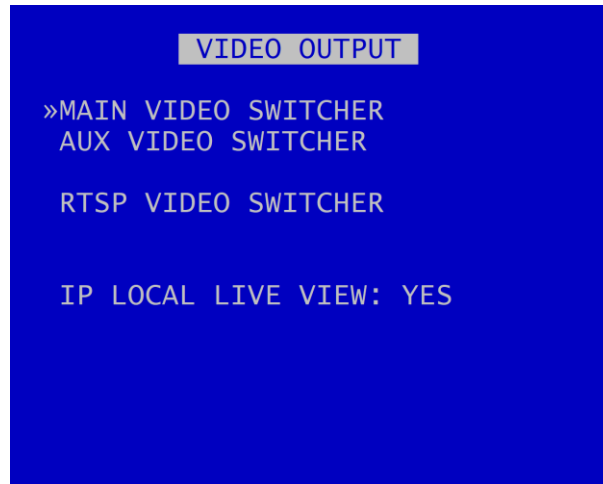

VIDEO OUTPUT menu controls the automatic switching and dwell time of cameras on the two video outputs:

[MAIN VIDEO SWITCHER](#) – main video output

[AUX VIDEO SWITCHER](#) – auxiliary (secondary) video output

[RTSP VIDEO SWITCHER](#) – stream video via RTSP.

IP LOCAL LIVE VIEW – select YES or NO to make IP camera live view available on the [MAIN VIDEO SWITCHER](#).

NB: the DVR will reboot when the IP LOCAL LIVE VIEW selection is changed.

To view camera setup on the Reviewer:

When in Auto mode (selected by pressing the Auto key on the [Reviewer](#)), the video output will switch between the configured cameras for the set period of time.

For analogue (SD) cameras, single camera output is selected by pressing the camera number on the [Reviewer](#).

IP camera view is selected via the menu page MAIN MENU > [IP CAMERA VIEW](#).

3.1.10 Main Video Switcher

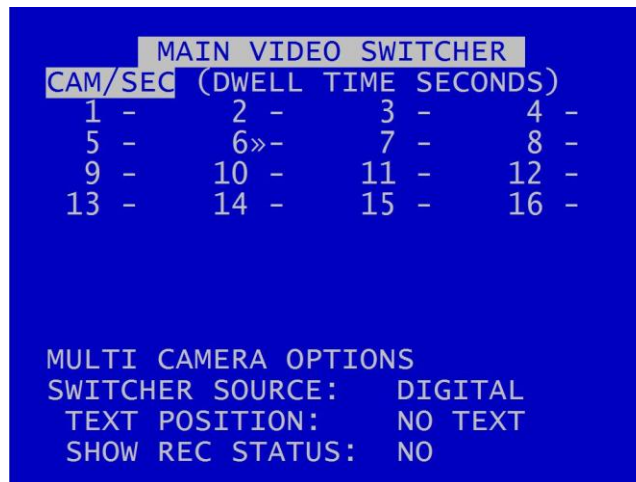

MAIN VIDEO SWITCHER menu controls the video output on the Main Switcher.

CAM/SEC – Set the desired camera DWELL time (in seconds) next to each camera that is to be included in the switcher sequence.

MULTI CAMERA OPTIONS – allows the simultaneous viewing of a number of cameras at the same time. The output is split into tiles per camera. Multi view can be included in the Auto switching sequence.

SWITCHER SOURCE – select from DIGITAL or ANALOG. ANALOG is a live camera image from the selected camera(s). DIGITAL is a processed image from the selected camera.

TEXT POSITION – Sets the position of the time/date text on the screen. Options are: NO TEXT, BOTTOM HIGH, BOTTOM MIDDLE, BOTTOM LOW, TOP HIGH, TOP MIDDLE, TOP LOW.

SHOW REC STATUS – Select YES/NO to determine whether the recording status is shown on the embedded text in MULTI CAMERA setup and also on each individual camera.

NB: this does not affect the date/time being recorded into the images; this is set in [SETTINGS MENU / SYSTEM SETTINGS > CAMERA SETTINGS](#).

3.1.10.1 Multi Camera Options



[MULTI CAMERA SETUP](#) – configures which cameras are to be displayed simultaneously in the MULTI CAMERA VIEW.

[MULTI CAMERA VIEW](#) – provides a “preview” of the multi camera setup.

MULTI CAMERA (SEC) – sets the number of seconds for which the MULTI CAMERA VIEW is displayed. Available options are: 1SEC, 2, 3, 4, 5, 10, 20, 30SECS.

TEXT POSITION – sets the position of the time/date text on the MULTI CAMERA view. Select from NO TEXT, BOTTOM HIGH, BOTTOM MIDDLE, BOTTOM LOW, TOP HIGH, TOP MIDDLE, TOP LOW.

SHOW REC STATUS - Select YES/NO to determine whether the recording status is shown on the embedded text in MULTI CAMERA setup. and also on each camera individually.

3.1.10.2 Multi Camera Setup

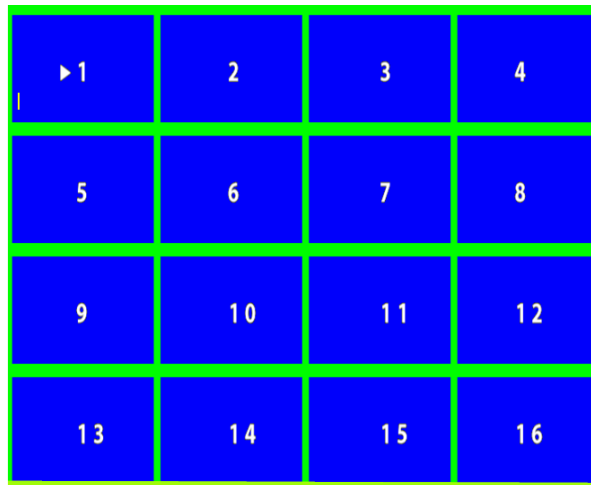

Configures which cameras are to be displayed simultaneously. Each tile can be set to display a sixteenth view of a camera. If the same camera number is set to four tiles in a square then a quarter view will be shown.

Cameras for each tile are selected using the left/right Menu Navigation keys on the [Reviewer](#) to scroll through the camera number options. Move along/up/down the tiles using the up/down Menu Navigation keys.

HINT: Pressing the Auto key on the Reviewer will switch the video output between the configured cameras for the set period of time. Single camera output is selected by pressing the camera number on the Reviewer.

3.1.10.3 Multi Camera View

MULTI CAMERA VIEW displays multiple camera outputs as per the current settings configured in [MULTI CAMERA SETUP](#).

3.1.11 Auxiliary Video Switcher

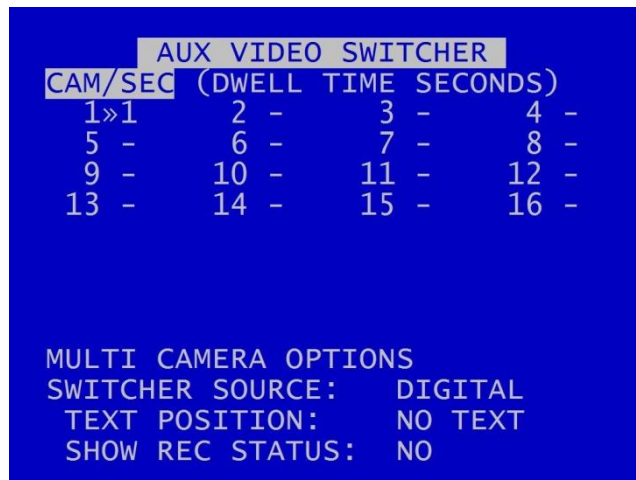

AUX VIDEO SWITCHER configures the settings for the auxiliary (secondary) video output.

Different versions of the V400 have different features available on AUX VIDEO SWITCHER as follows:

T708 (8-camera version) – AUX VIDEO provides a secondary switcher output for video only.

T712 (12-camera) and T716 (16-camera) – AUX VIDEO provides a secondary switcher output for both video and MULTI CAMERA views.

AUX VIDEO SWITCHER settings, e.g. for MULTI CAMERA (12 and 16-camera V400 models only) and TIME/DATE POSITION are configured in the same way as for [MAIN VIDEO SWITCHER](#).

SWITCHER SOURCE – select DIGITAL or ANALOGUE.

Displaying a JPEG image

To display a JPEG image on the Aux video switcher:

- The JPEG image should be sized 720 x 576
- The image should be stored on the HDD with the file name “logo.jpg”
- The user will need to select AUX IMAGE function against the required ALARM INPUT

3.1.12 RTSP Switcher

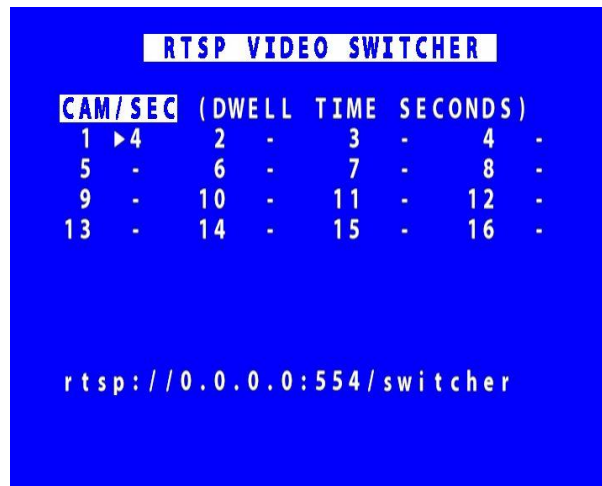

The Real Time Streaming Protocol (RTSP) is a network protocol allowing video to be streamed to an RTSP client.

NB: RTSP uses 5IPS (multiplied by the number of cameras when switching). This therefore has an impact on the overall IPS availability for other DVR functions.

If the DVR has resources to enable RTSP, then the server URL will be displayed on this menu page. Otherwise, no URL will be displayed and the menu page will state that RTSP is disabled.

The RTSP stream can be viewed within VLC using the URL address shown on the screenshot above.

Individual SD cameras can be configured to stream their video for a pre-set time before switching to the next camera.

NB: IP cameras cannot be streamed over RTSP.

3.2 Settings Menu

3.2.1 System Settings

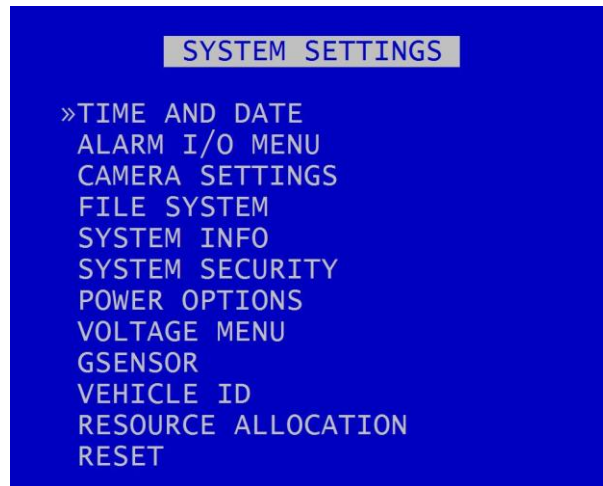

The SYSTEM SETTINGS MENU gives access to configure various system settings and to view system information.

3.2.2 Time And Date



TIME AND DATE menu displays the current time/date. New times/dates can be set by entering new values using keys 0-9 on the [Reviewer](#).

SET CLOCK TO THESE SETTINGS – confirms and sets the new time/date.

The date display MODE can be switched between DD/MM/YY and MM/DD/YY. The chosen format will be used for date entry and display throughout the system.

NB: date and time settings cannot be changed while the unit is recording.

Summer time adjustment can be selected for UK, EUR USA , NZ and OFF.

Summer time adjust automatically updates the system to daylight saving time, valid for the country selected. Adjustments are applied even if the system was powered off during the time change.

When the clock is put forward, the time is now summer time, which is winter time +1 hour. When the clock is put back, time reverts to winter time.

UK - At 1am on the last Sunday in March, the clock is put forward an hour. At 2am on the last Sunday in October, the clock is put back an hour.

Central Europe - At 2am on the last Sunday in March, the clock is put forward an hour. At 3am on the last Sunday in October the clock is put back an hour.

USA - At 2am on the second Sunday in March, the clock is put forward an hour. At 2am on the first Sunday in November, the clock is put back an hour.

NZ – at 2am on the last Sunday in September, the clock is put forward an hour. At 3am on the first Sunday in April, the clock is put back an hour.

NB: when time or date are changed, a hard disk re-format is recommended in order to reset the meta file.

3.2.3 Alarm Inputs/Outputs menu

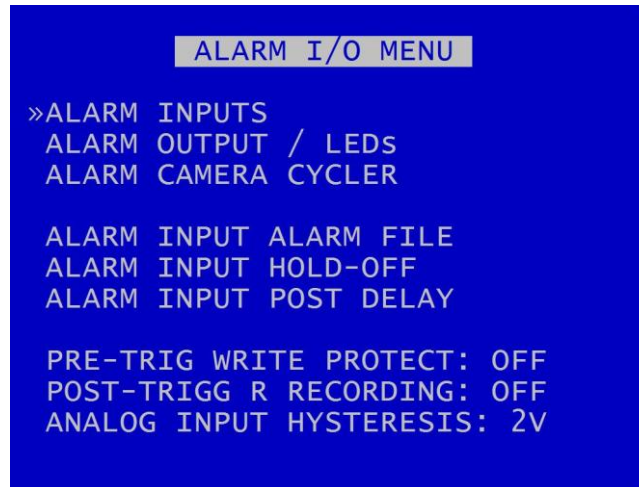

Alarm Inputs and Outputs can be configured as per the [ALARM INPUTS/OUTPUTS](#) menu in settings for [ALARM RECORDING](#).

3.2.4 Camera Settings



CAMERA SETTINGS menu configures the [CAMERA TEXT](#) labels, timestamp position, [VIDEO SETTINGS](#) and camera disconnect time.

TIMESTAMP POS - the timestamp can be positioned either below (BOTTOM) or above (TOP) the main area of the recorded image and fine adjustment of position made with LOW/MIDDLE/HIGH settings. The timestamp can also be turned off (select NO TIMESTAMP) and will not be written in to the recorded images.

[VIDEO SETTINGS](#) - controls the video standard (PAL or NTSC).

CAMERA DISCONNECT TIME – this option allows disconnected cameras to be reported as connected for a set time period. This is useful in cases where a camera can take a while to boot and send its signal. If there is no signal after the timeout, the camera is treated as disconnected and is flagged in the service log. Available options are OFF, 10 SEC, 30 SEC, 1 MIN, 2 MIN, 5 MIN. After the selected time period has expired, any analogue (SD) camera disconnected from the DVR for a period of 2 seconds will be flagged as “Camera Disconnected” in the service log.

3.2.4.1 Camera Text

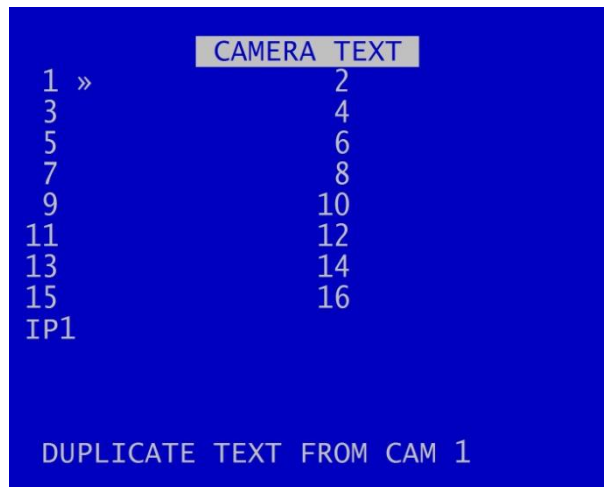

Individual text for each camera can be inserted above the timestamp. This text, along with timestamp, will be shown on recorded images.

12 user-defined characters can be input per camera. Enter text using the Text and Number Input keys on the [Reviewer](#).

DUPLICATE TEXT – feature is available for copying down text from camera 1 to all remaining cameras.

3.2.4.2 Video Settings – PAL and NTSC

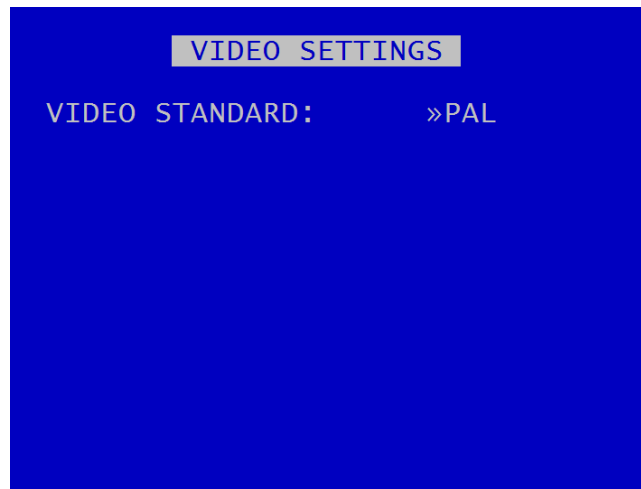

VIDEO SETTINGS menu controls the video standard, i.e. whether the unit is to operate with PAL or NTSC cameras.

NB: after changing the video standard setting, the unit will automatically reboot after 5 seconds for the change of setting to take effect. A red “Reboot Required” warning will flash on the screen before the reboot commences.

3.2.5 File System

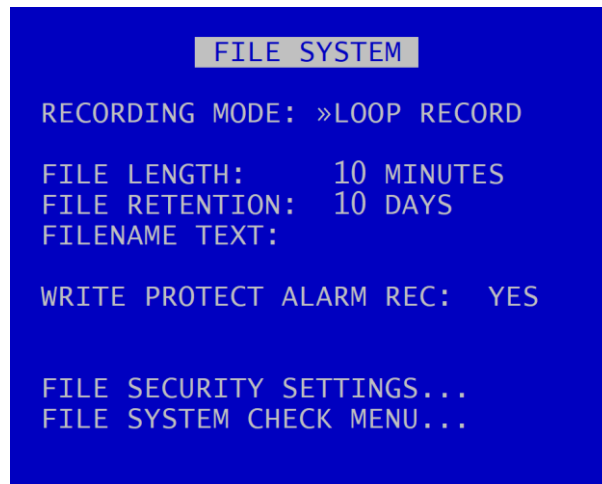

FILE SYSTEM MENU sets the parameters of the file system and how files are laid to disk.

RECORDING MODE sets either:

- LOOP RECORD (oldest files will be overwritten first when the hard disk cartridge is full) or
- SINGLE PASS recording (recording will stop when the hard disk cartridge is full).

FILE LENGTH – controls how often a new file is created. A new file is created each time recording starts. The file will be named with the date/time when the recording started. If continuous recording, the next file will be started as per the file length settings or when next time boundary is met. For example when using 10 minute files, if recording starts at 10:03, the first file will contain 7 minutes of video and the second file will be started at 10:10. New files will then be created every 10 minutes, i.e.10:20, 10:30 etc. Files can be configured for: 1 MINUTE, 5 MINUTES, 10 MINUTES, or 1 HOUR.

NB: File size is limited to 4GB. After this limit is reached, a new file will be created.

FILE RETENTION – sets the number of days for which footage remains on the disk. Footage older than the selected time period will be deleted. Selectable options are 10, 20, 30, 40, 50, 60 days pls ALL FILES option to retain all files. The default is ALL FILES will be retained.

FILENAME TEXT – prefixes the recording files with up to 12 user defined characters (0-9, A-Z, space). Text and numbers are entered using the [Reviewer](#).

WRITE PROTECT ALARM REC – selects whether alarm recording files are write protected. If alarm files are write-protected they will not be deleted on LOOP recording. Select YES/NO.

[FILE SECURITY SETTINGS](#) – configures options for file password and encryption.

[FILE SYSTEM CHECK](#) menu – configures whether the file system is checked (and possibly corrected) at power up and also if a system log is created.

3.2.5.1 File Security Settings



This menu provides options for setting file security on the DVR.

NB: any settings configured here on the DVR menu will be over-written by LANLink if LANLink is managing the security settings for the DVR. Contact Timespace for further details.

Select from the 3 available levels of file protection:

DISABLED – No file protection.

PASSWORD – the files are password protected.

PASS. & ENCRYP. – the files are password protected and the audio and video data in the file is encrypted.



3.2.5.2 Setting a password

A password length from 1 – 14 characters is valid. Timespace recommends a password of 5 or more characters. All characters that can be entered from the [Reviewer](#) are valid:

NB: the default old password is 0000 (four zeros).

SET PASSWORD will set the new password and activate the selected File Security Settings.

3.2.5.3 DVR Menu and Playback Protection:

Optionally set a MENU and PLAYBACK Pin can be set (see SETTINGS MENU > SYSTEM SETTINGS > [SYSTEM SECURITY](#)). This prevents unauthorised access to the DVR menu settings, but permits controlled access eg for engineers in the field to review camera angles on a [Reviewer](#) and amend settings.

3.2.5.4 File System Check

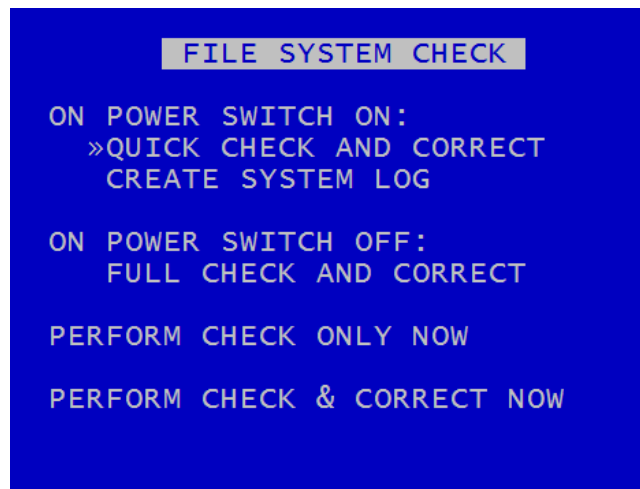

FILE SYSTEM CHECK menu configures whether the file system is checked (and possibly corrected) at power up and also if a system log is created.

ON POWER SWITCH ON – select from options:

- No check / Quick check and correct / Full check and correct
- Create system log / do not create system log

ON POWER SWITCH OFF:

- No check / Quick check and correct / Full check and correct

PERFORM CHECK ONLY NOW will check the files and file system and report any errors but will not attempt to fix anything.

PERFORM CHECK AND CORRECT NOW will perform a file and file system check and fix any errors that are found. It also rewrites the FAT and BOOT sectors.

NB: No XBA files/data are deleted during the check and correct function.

3.2.6 System Info

```

SYSTEM INFO
1.4.0.257 OPERATING SYSTEM
114/5.00.14/C FIRMWARE
1500.30 SIZE IN GIGABYTES
0.01 % USED
0.01 % WRITE PROTECTED
2 FILES
08/09/16 START DATE
08/09/16 END DATE
0.00 DAYS RECORDING
38 DEG C TEMP
V400-16 H/W VERSION
130853 SERIAL NUMBER

```

SYSTEM INFO menu displays information about the system;

OPERATING SYSTEM – Currently installed/running software version.

FIRMWARE – Currently installed/running firmware version (FPGA build / H264 codec / PCB Rev).

SIZE IN GIGABYTES – Total size of installed hard disk cartridge.

USED – Percentage of hard disk cartridge used by any files.

WRITE PROTECTED – Percentage of cartridge used by write protected files.

FILES – Number of XBA files on the hard disk cartridge.

START DATE – The date of the first (oldest) file on the cartridge.

END DATE – The date of the last (newest) file on the cartridge.

DAYS RECORDING - The number of days between the start/end date. **NB:** that there may not be continuous recording files between the start/end dates.

TEMP – the temperature of the V400 unit.

H/W VERSION – The hardware model number of the DVR.

SERIAL NUMBER - Displays the V400 serial number.

3.2.7 System Security



SYSTEM SECURITY menu sets a pincode to restrict user access to five key areas of the system. A read-only access can be set that allows files to be viewed and limited features to be used. For each area, select YES/NO.

RECORD - If set to YES, the record button on the front panel and the [Reviewer](#) are pincode protected.

MENU - If set to YES, access to the menu system is pincode protected.

PLAY – If set to YES, the controls to review recorded footage are pincode protected.

SWITCHER - If set to YES, the button to activate auto switcher mode is pincode protected.

READ ONLY - If set to YES, the user cannot change any setting on the V400. The menu system can be browsed but no settings changed. If a setting change is attempted, the element will flash in RED for 2 seconds and not be changed. To exit read only mode, change read only to NO, at which point you will be prompted for the pincode.

If access to a pincode protected function is attempted, the user is prompted with the ENTER PINCODE screen. On correct pincode entry the pincode protection is temporarily disabled while that function is being used.

[CHANGE SYSTEM PIN](#) – provides options for changing the pincode.

[FTP/TELNET USERS](#) – gives options to access the V400 by FTP/Telnet.

3.2.7.1 Change System PIN



CHANGE PIN menu provides options for changing the pincode.

Pincode can be changed by first entering the current pincode, followed by the new one (entered twice for verification). Pincode format is four digits only 0-9. Enter numbers using the [Reviewer](#).

Default pincode is **0000** (four zeros).

In the event of a complete pincode lockout, contact your installer or Timespace for a master unlock code; email support@tspace.co.uk

3.2.7.2 FTP/Telnet User Passwords

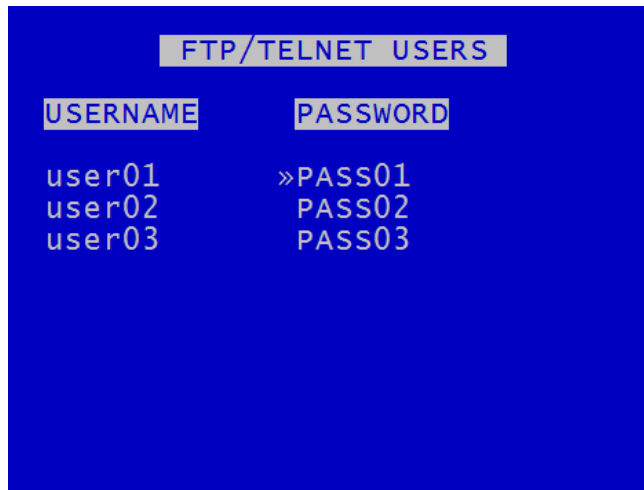

The screenshot shows a blue terminal window with the title "FTP/TELNET USERS". Below the title, there are two columns: "USERNAME" and "PASSWORD". The first row shows "user01" with a password of "»PASS01". The second row shows "user02" with a password of "PASS02". The third row shows "user03" with a password of "PASS03".

USERNAME	PASSWORD
user01	»PASS01
user02	PASS02
user03	PASS03

FTP/TELNET USERS MENU gives the option to have three different passwords to access the V400 via FTP/TELNET.

The usernames are fixed; however the passwords can be set as required, and are case sensitive.

3.2.8 Power Options

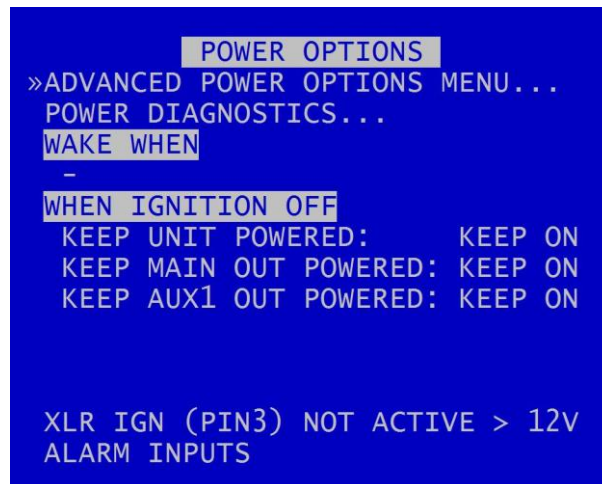

POWER OPTIONS menu configures the behaviour of the DVR when power is applied, when power is removed and when an input trigger is detected. The DVR has a built-in GSensor for detecting motion, and can use the GSensor readings to wake up and/or shut down the DVR.

The DVR can be configured for different power scenarios, eg:

- to stay powered for a period of time when the ignition is turned off, and
- to then wake upon ignition;
- to sleep when no motion is detected and
- to then wake upon motion;
- to wake at a specified time of day

In addition, the DVR can be configured to either SHUTDOWN or STANDBY when ignition is off, and for cameras to stay ON or switch OFF if the unit is in STANDBY mode.

[ADVANCED POWER OPTIONS MENU](#) – provides further selections for waking the DVR, and for configuring behaviour when the ignition is switched on or off, and in low-battery situations.

[POWER DIAGNOSTICS](#) menu displays the current power consumption, broken down into components.

WAKE WHEN – displays current wake prompts, ie those selected in the [ADVANCED POWER OPTIONS](#) menus. Depending on the settings the user has configured, WAKE WHEN will show either IGNITION, MOTION, TIME or a combination of these.

WHEN IGNITION OFF – sets the behaviour of the DVR when ignition is turned off. Options for SHUTDOWN or STANDBY are selected in the [ADVANCED POWER OPTIONS MENU](#) > [ADVANCED IGNITION OFF MENU](#).

NB: In order for the DVR to operate on ignition, the ignition feed should be connected to one of the DVR's [ALARM INPUTS](#) and the [ALARM INPUT FUNCTION](#) set to IGNITION with the active voltage set accordingly.

If this has not been done, the POWER OPTIONS menu will display either:

- XLR IGN (PIN 3) NOT ASSIGNED
- XLR IGN (PIN 3) NOT ACTIVE
- XLR IGN (PIN 3) ACTIVE

The XLR IGN is located on pin 3 of the 5-pin power-in XLR (see [Figure](#)).

KEEP UNIT POWERED – Select from options KEEP ON, 1 MIN, 5, 10, 15, 20, 30, 35, 40, 45, 50, 1 HOUR, 2 HOURS, 3 HOURS, 4 HOURS. NB if STANDBY has been selected in the [ADVANCED IGNITION OFF MENU](#), this KEEP UNIT POWERED option will be replaced by UNIT STANDBY, with the same selectable time options.

KEEP MAIN OUT POWERED options – configures time period for powering the main video (monitor) output. Select from KEEP ON, OFF, 5MINS, 10, 15, 20, 30, 35, 40, 45, 50MINS, 1HOUR, 2HOURS, 3HOURS, 4HOURS.

KEEP AUX1 OUT POWERED options – configures time period for powering the auxiliary video (monitor) output. Select from KEEP ON, OFF, 5MINS, 10, 15, 20, 30, 35, 40, 45, 50MINS, 1HOUR, 2HOURS, 3HOURS, 4HOURS.

[ALARM INPUTS](#) – provides a quick link to the ALARM INPUTS page.

3.2.8.1 Advanced Power Options

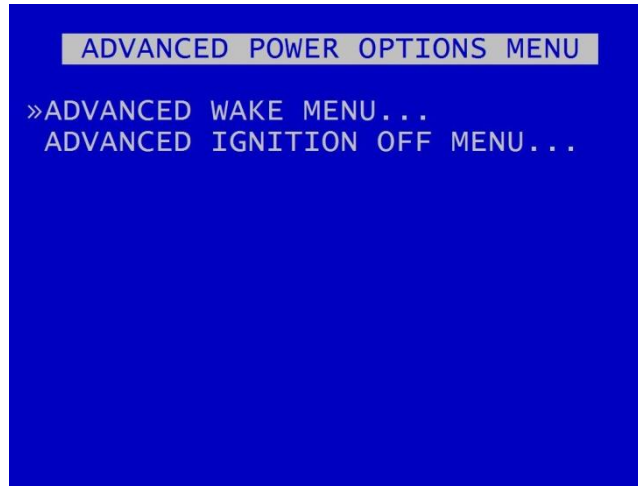

ADVANCED POWER OPTIONS MENU – provides links to the [ADVANCED WAKE MENU](#) and the [ADVANCED IGNITION OFF MENU](#).

3.2.8.2 Advanced Wake Menu

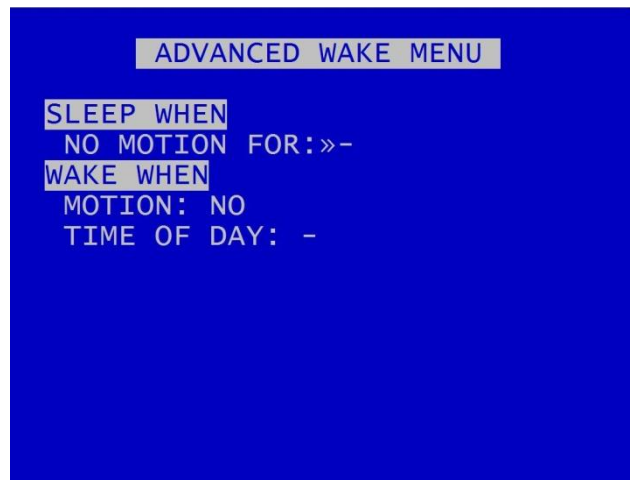

The V400 has a built in [G-SENSOR](#) for recording and detecting motion. The V400 can use the GSENSOR readings to wake up and/or to shutdown.

SLEEP WHEN – sets the V400 to sleep when NO MOTION is detected for a period of time. Select from available options: 1MIN, 2, 5, 10, 30, 35, 40, 45, 50MINS, 1HOUR, 2 HOURS.

NB: When setting the V400 to sleep on NO MOTION, ensure that one of the WAKE triggers is turned on e.g MOTION, TIME OF DAY or an ALARM INPUT. If a WAKE WHEN setting is not enabled, the V400 will sleep until the next power cycle.

WAKE WHEN - sets the V400 to wake upon given triggers.

MOTION – will be automatically shown as YES if the above SLEEP WHEN NO MOTION FOR setting has been selected. .

TIME OF DAY – can be set to trigger the V400 to wake at a particular time. Times can be set using the right and left Menu Navigation buttons on the [Reviewer](#) to scroll through times in 15min increments.

HINT: Setting the wake up time is a useful feature for waking the V400 up during the night to download recorded footage via [LANLink](#) .

3.2.8.3 Advanced Ignition Off

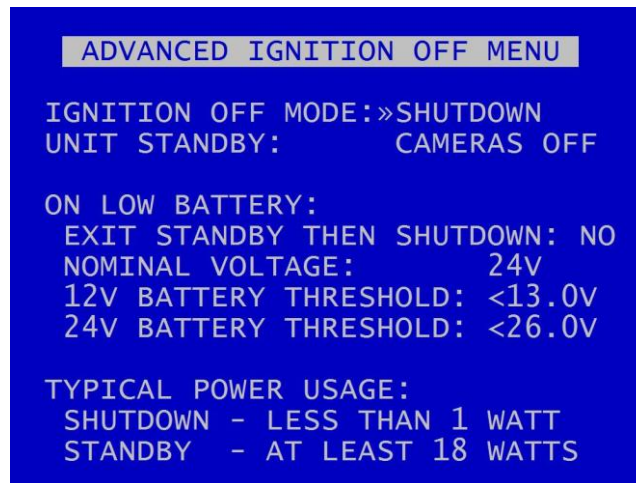

ADVANCED IGNITION OFF MENU provides options for the unit to be set to SHUTDOWN or STANDBY mode when ignition is off.

1. Ignition ON > OFF

IGNITION OFF MODE – select SHUTDOWN or STANDBY. If set to SHUTDOWN, after the timeout period specified by KEEP UNIT POWERED (see main [POWER OPTIONS](#) menu page), the DVR will shut down and run in a low-power mode.

If set to STANDBY, after the timeout period specified by UNIT STANDBY settings (see main [POWER OPTIONS](#) menu page), the DVR will enter STANDBY mode where recording is disabled (the DVR otherwise functions normally).

If STANDBY is selected, an advisory warning will be displayed as below:

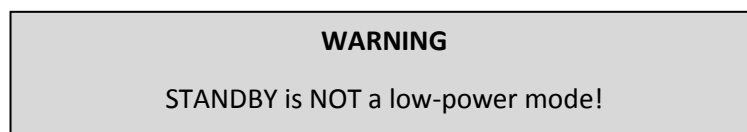

In STANDBY mode there is also a power-saving option to switch CAMERAS OFF (NB this only applies to the analogue cameras). The power requirements in STANDBY will depend on the MAIN and AUX POWERED settings (see main [POWER OPTIONS](#) menu page).

ON LOW BATTERY – when in STANDBY mode, the DVR can be set to exit STANDBY mode and to SHUTDOWN if the battery voltage level dips below the threshold voltage.

Set the nominal voltage of the battery (input voltage) to either 12V or 24V. Then the relevant 12V or 24V battery threshold as required.

The voltage must dip below the threshold for a few seconds before STANDBY mode will be exited and the DVR will SHUTDOWN.

Typical power usage for the SHUTDOWN and STANDBY options are:

SHUTDOWN – less than 1W

STANDBY – at least 18W

2. Ignition OFF > ON

If the DVR is SHUTDOWN and in low-power mode, the DVR will power-up.

If the DVR is STANDBY, the standby mode will be exited and standard operation is resumed. The power to analogue cameras will be restored.

Notes

- i. If the DVR is set to perform a file system check ON POWER SWITCH OFF (see FILE SYSTEM > FILE SYSTEM CHECK MENU > ON POWER SWITCH OFF), the DVR will perform this check in both SHUTDOWN and STANDBY modes.
- ii. If the ignition is switched on during the file system check the check is aborted.
- iii. If the ignition is switched on during the SHUTDOWN before the DVR enters low-power mode, then the SHUTDOWN is aborted and standard operation is resumed.

3.2.8.4 Power Diagnostics

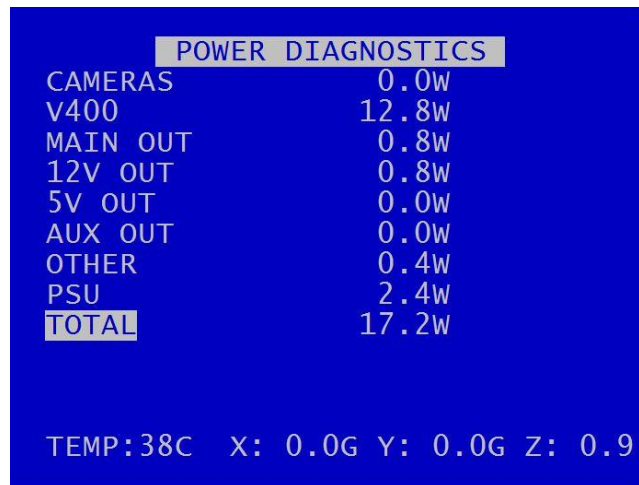

The screenshot shows a blue background with white text. At the top, 'POWER DIAGNOSTICS' is highlighted in a grey box. Below it, a list of power-consuming components and their values in Watts (W) is shown. At the bottom, sensor data for temperature and G-sensor coordinates is displayed.

CAMERAS	0.0W
V400	12.8W
MAIN OUT	0.8W
12V OUT	0.8W
5V OUT	0.0W
AUX OUT	0.0W
OTHER	0.4W
PSU	2.4W
TOTAL	17.2W

TEMP:38C X: 0.0G Y: 0.0G Z: 0.9

POWER DIAGNOSTICS page displays the current power consumption, broken down into various sections e.g. Cameras, GPS.

It also displays current temperature and GSensor co-ordinates.

3.2.8.5 Voltage Menu

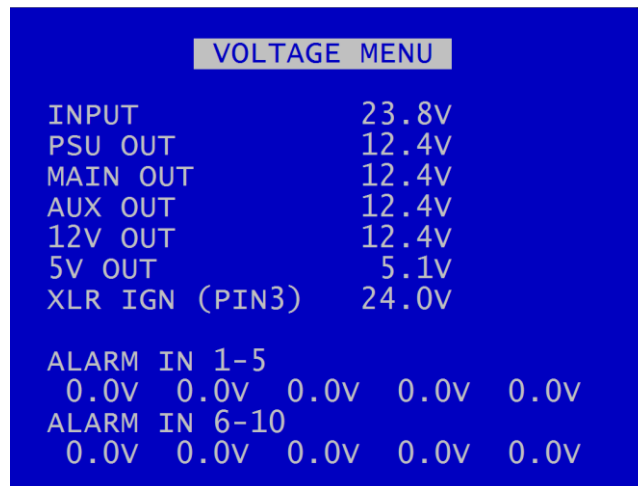

The screenshot shows a blue background with white text. At the top, the title 'VOLTAGE MENU' is displayed in a white box. Below the title, the following voltage readings are listed:

INPUT	23.8V
PSU OUT	12.4V
MAIN OUT	12.4V
AUX OUT	12.4V
12V OUT	12.4V
5V OUT	5.1V
XLR IGN (PIN3)	24.0V
ALARM IN 1-5	
0.0V	0.0V 0.0V 0.0V 0.0V 0.0V
ALARM IN 6-10	
0.0V	0.0V 0.0V 0.0V 0.0V 0.0V

VOLTAGE MENU page displays the current Voltage supply, broken down into various sections e.g. Main video output, Alarm Inputs

NB: The POWER DIAGNOSTICS and VOLTAGE MENU pages may be useful during installation and troubleshooting.

3.2.9 GSensor

GSENSOR			
BRAKE	G	ACC	G
01:06	0.02	04:59	0.02
01:00	0.02		
00:56	0.02	LAT	G
00:51	0.02	01:15	0.03
00:45	0.02	01:09	0.03
00:40	0.02	01:00	0.03
UP	G	00:54	0.03
04:59	0.03	00:49	0.03
02:37	0.03	00:42	0.03
		»RESET	ALARM
GSENSOR	SETUP	RESET	READINGS

GSENSOR menu configures settings for the V400’s built-in Timespace GSensor/accelerometer.

The GSensor is a device that provides X, Y and Z axes data internally to the V400. Data is displayed recorded into each image along with optional GPS data.

GSensor readings are displayed for;

- BRAKE - Measurement of decreasing forward motion.
- ACC - Measurement of increasing forward motion.
- LAT - Measurement of lateral movement.
- UP - Measurement of upwards motion.

[GSENSOR SETUP](#) - sets up the GSensor positioning.

- RESET READINGS - Clears all current readings within this hour.
- RESET ALARM - Clears the alarm condition.

3.2.9.1 GSensor Setup

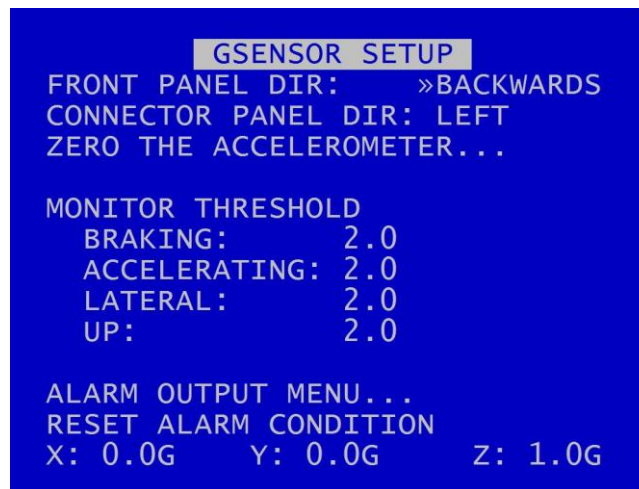

GSENSOR SETUP menu displays the GSensor configuration. The GSensor is calibrated as part of the manufacturing process in a controlled environment and should not require calibration during the installation process.

Set the FRONT PANEL DIRECTION, e.g. front panel set to FORWARDS means the V400 front panel is facing the front of the vehicle.

The CONNECTOR PANEL DIRECTION must then be set to LEFT, RIGHT, UP, DOWN, FORWARDS or BACKWARDS depending on the mounting position.

ZERO THE ACCELEROMETER– Once the panel directions are set, the GSensor orientation must be confirmed. Select [ZERO THE ACCELEROMETER](#) and follow the instructions on the screen.

GSensor threshold triggers (for BRAKING, ACCELERATING, LATERAL and UP) can be configured from 0.1 - 2.0. If the set value is exceeded an alarm can be raised (used in conjunction with alarm outputs). A link to the [ALARM OUTPUT](#) menus gives quick access to configure the required action.

RESET ALARM CONDITION – clears the alarm condition.

3.2.9.2 Zero the Accelerometer

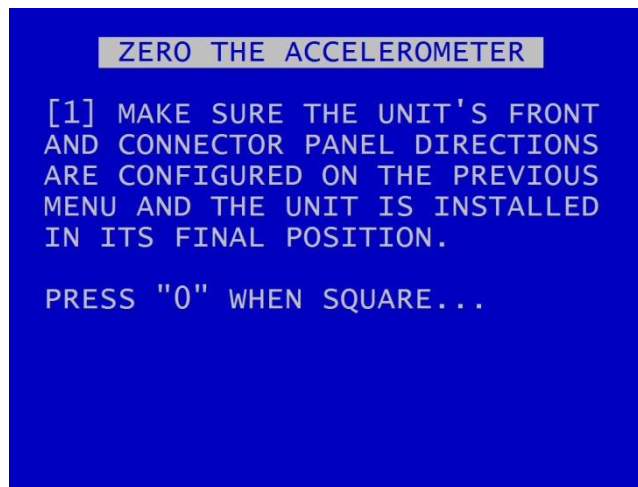

Once the V400 is installed in its final operating position, the GSensor readings must be zeroed by entering "0" when on the ZERO THE ACCELEROMETER screen.

A second screen will confirm that this has been done.



3.2.10 Vehicle ID

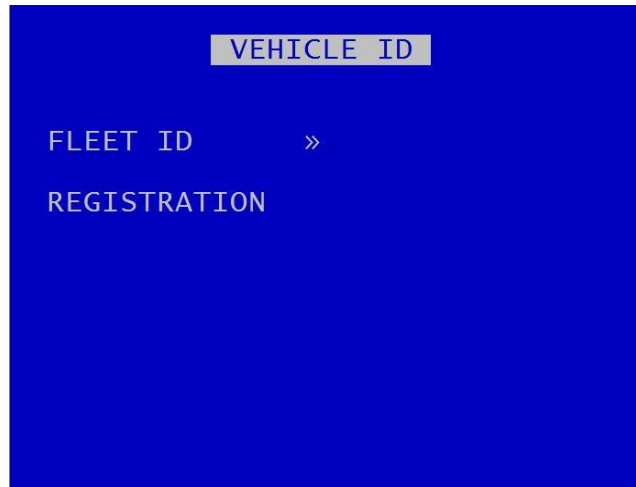

This menu page allows entry of the vehicle's fleet ID number and registration number. This is recorded in system and health logs and makes it easier when using LANLink to identify the vehicle in which the recorder is fitted.

Vehicle ID and registration number details can be entered using the Text and Number Input keys on the [Reviewer](#).

3.2.11 Resource Allocation

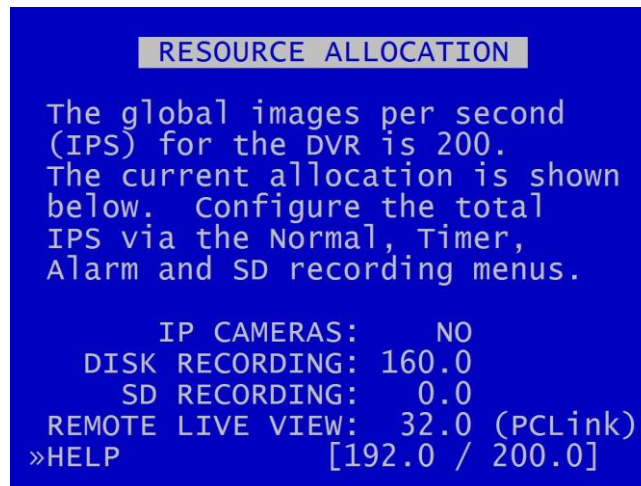

The RESOURCE ALLOCATION page provides details of the images per second (IPS) allocation as currently configured on the V400. The IPS allocation values shown indicate the quantity of IPS currently assigned to IP Cameras, Disk Recording, SD Recording and Remote Live View.

The IPS allocation across e.g. cameras, HD cartridge and SD card recording can be configured via the [NORMAL RECORDING](#), [TIMER RECORDING](#), [ALARM RECORDING](#), [SD RECORDING](#) and [IP CAMERAS](#) menus.

The IPS value shown for Disk Recording is the highest IPS configured on the [NORMAL RECORDING](#), [TIMER RECORDING](#) OR [ALARM RECORDING](#) menus.

The IPS value shown for SD Recording is the IPS configured on the [SD Recording](#) menu. **NB:** if the DVR is configured for [HD Mirror Mode](#), the SD Recording resource will be shown as 0IPS.

The IPS value shown for Remote Live View is automatically allocated and is the actual IPS currently set for this mode. If is not in use, the table will display 0.0 IPS.

HELP – provides further explanations on IPS allocation, and global IPS limits for the different models of DVR.

3.2.11.1 Resource Allocation Menu

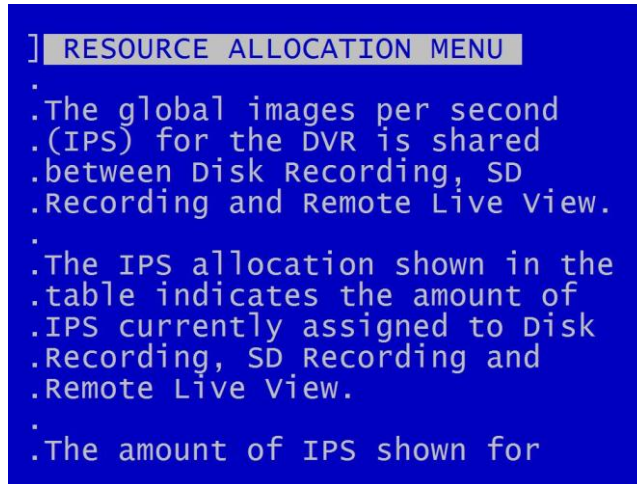

The global total number of images per second (IPS) for the V400 is shared between Hard Disk Recording, SD card recording, and Remote Live View. For the different versions of the V400 unit the global IPS limits are as follows:

V400 model	Global IPS limit
V400-08	100
V400-12	150
V400-16	200
V400-16S	100

The IPS allocation values shown on the [RESOURCE ALLOCATION](#) page indicate the quantity of IPS currently assigned to Disk Recording, SD Recording and Remote Live View.

The IPS value shown for Disk Recording is the highest IPS configured on the [NORMAL RECORDING](#), [TIMER RECORDING](#) OR [ALARM RECORDING](#) menus.

The IPS value shown for SD Recording is the IPS configured on the [SD Recording](#) menu.

The IPS value shown for Remote Live View is automatically allocated and is the actual IPS currently set for this mode. If Remote Live View is not in use, the table will display 0.0 IPS.

[RTSP](#) will use 5 IPS (multiplied by the number of cameras if switching).

If the total global IPS is allocated to Disk Recording then no IPS will be available for SD Recording or Remote Live View.

If the total global IPS is allocated to Disk Recording and SD Recording, then no IPS will be available for SD Recording or Remote Live View.

If the IPS available for Remote Live View does not meet the camera requirement for Remote Live View, then as many cameras as possible will be configured using available remaining IPS.

If a priority camera is required, then it will be configured first. Remaining cameras are configured by camera number, lowest to highest.

A minimum of 2.0 IPS is required to show each live camera over Remote Live View.

Configure the V400 IPS via the [NORMAL RECORDING](#), [TIMER RECORDING](#), [ALARM RECORDING](#), [SD RECORDING](#) and [IP CAMERAS](#) menus. The remaining available IPS (up to the global maximum) will be available for Remote Live View.

3.2.12 Reset



The RESET menu provides options for resetting the system and/or deleting files. The following options are available.

[DELETE ALL RECORDING FILES](#)
[SECURE DISK WIPE](#)

WARNING: THERE IS NO “UNDO” FUNCTION IF THESE OPTIONS ARE SELECTED.

[USER PROFILES](#) – three User Profiles can be configured with different settings for different uses or recording modes.

MENU LANGUAGE – can be set between ENGLISH (default) or FROM DISK.

When FROM DISK is selected, the V400 will load a language file from the cartridge with MENU and HELP text translated into a given language. The language template is pre-loaded to the cartridge by the user at the point of installation.

Contact Timespace for details of currently available translations.

The language file will not be removed when running [DELETE ALL RECORDING FILES](#).

NB: A power cycle is required before the new language settings will take effect.

3.2.12.1 Delete All Recording Files

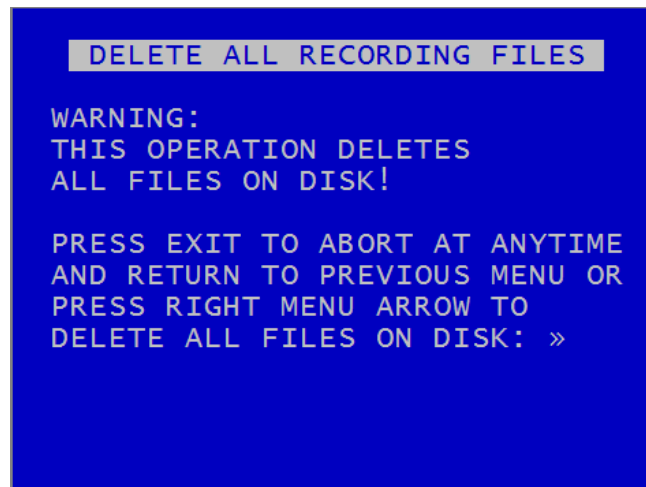

DELETE ALL RECORDING FILES – will remove all recordings from the hard disk, including write-protected files.

Only select this option if you want to completely remove all recordings – there is NO undo option. Press the right menu button to go to a warning screening, press right again to carry out this action. Pressing Menu Exit on the [Reviewer](#) will abort this procedure.

WARNING: THERE IS NO “UNDO” OPTION. SELECTING “DELETE ALL FILES ON DISK” WILL COMPLETELY REMOVE ALL RECORDINGS.

3.2.12.2 Secure Disk Wipe

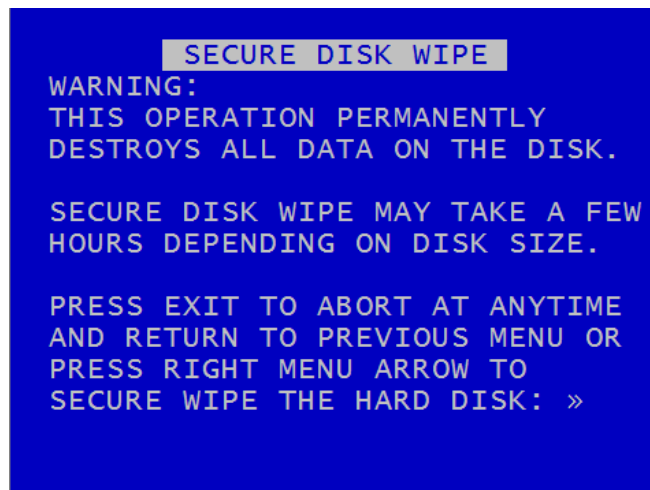

SECURE DISK WIPE – will permanently delete all recording files on the hard disk. This option should only be selected if files need to be completely destroyed.

WARNING : SELECTING “SECURE WIPE THE HARD DISK” WILL MEAN NO FILES CAN BE RECOVERED.

A final warning message will appear before this function is carried out. Pressing Menu Exit on the [Reviewer](#) will abort this.

3.2.12.3 User Profiles



Three User Profiles can be configured with different settings for different uses or recording modes. This gives the user an easy way of quickly switching between types of recording required without having to setup the V400 each time. Each profile can be named individually.

In addition to the three user profiles, the V400 Default menu settings can be loaded.

PROFILE – select between DEFAULT and USER 1, 2 or 3.

LOAD PROFILE – loads the profile selected above.

SAVE PROFILE will write the currently loaded settings back to the flash memory, using the selected PROFILE name.

Example; User sets up NORMAL recording with 1 camera 5IPS, HIGH quality. Go to the RESET menu and overwrite USER 1 with “1CAM HIGH”, then change the PROFILE to 1CAM HIGH and select SAVE PROFILE. Change settings for ALARM on 2 cameras, then overwrite USER 2 with “2CAM ALARM”, change the PROFILE to 2CAM ALARM and select SAVE PROFILE. You now have 2 user defined profiles to easily switch between by LOADING the specified profile.

HINT: Save up to 3 of your most common settings using the USER PROFILES to allow quick switching between different types of recording mode for different installations. e.g.

USER PROFILE 1 - Normal record 8 cameras with audio.

USER PROFILE 2 - Normal record 14 cameras with GPS and SMS alert.

USER PROFILE 3 - Alarm record 4 cameras based on an external input.

3.3 External Equipment Menu

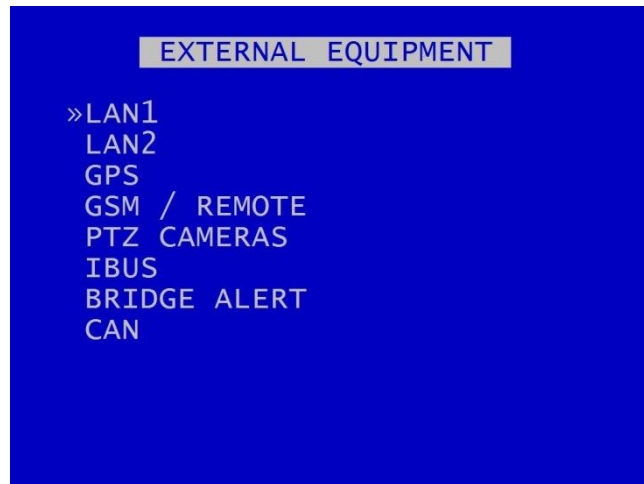

The V400 provides some common interfaces so that external equipment can be connected and configured for use with the DVR. For example;

LAN PORT 1 RJ45 socket for hard wiring a network cable, linking to a Wifi bridge or 3G router.

LAN PORT 2 RJ45 socket for connecting to the Transport for London diagnostic interface (**IBUS**) or the single supported IP Camera.

Molex connector for wiring a GPS unit, GSM modem or other equipment to take advantage of the V400 RS232 commands.

3.3.1 LAN1

```

LAN1
STATUS: CONNECTED
IP ADDRESS:      10.  0.200.200
SUBNET MASK:    255.255.  0.  0
GATEWAY:        10.  0.  0.254
DNS PRIMARY:    8.  8.  8.  8
DNS SECONDARY:  8.  8.  4.  4
USE DHCP:       NO

APPLY IP SETTINGS ABOVE
LAN IDLE TIMEOUT: 1 MIN
PING TEST...
MAC:             00:0f:b4:01:ff:25

```

The LAN1 menu Allows the user to change the parameters of the LAN system. LAN STATUS indicates whether the V400 is currently connected to a LAN or not.

IP ADDRESS - Enter the static (fixed) IP address that the V400 is to be assigned on the local area network. The default IP address is **10.0.0.200**

SUBNET MASK - Enter the subnet mask as applicable for the LAN the V400 is connected to. The defaults is 255.255.255.0

GATEWAY - Enter the gateway IP address of the default gateway the V400 will communicate with on the LAN.

DNS PRIMARY and SECONDARY – The Domain Name System (DNS) is set by default to Google’s primary and secondary servers. The DNS assigns domain names to IP addresses.

USE DHCP – select YES/NO. If there is a DHCP server on the network it will assign an IP address to the DVR.

APPLY IP SETTINGS ABOVE - select to confirm and apply configurations set above.

LAN IDLE TIMEOUT – select the duration for which LAN can be idle before prompting the unit to shut down. Options are 1 MIN, 2, 3, 4, 5 MINS (the default setting is 1 MIN).

[PING TEST](#) - enables the user to enter a destination IP address to send a network packet to testing connectivity.

MAC is the unique hardware identifier for the network interface on the V400.

3.3.1.1 Ping Test

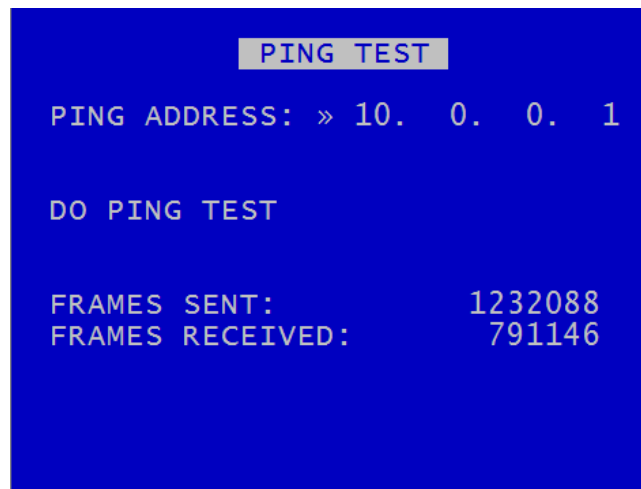

PING TEST menu enables the user to enter a destination IP address to send a network packet to testing connectivity.

FRAMES SENT / RECEIVED updates in real-time to show how many data packets are being transferred to and from the V400. These are global values and not specifically related to only the ping test.

3.3.2 LAN 2



The LAN 2 menu allows the user to change the IP address of the LAN2 port.

IP ADDRESS – enter the static (fixed) address that the V400 is to be assigned to on the secondary local area network. The default IP address is 192.168.10.30.

NB: the LAN2 port has dual use for [IBUS](#) and [IP CAMERA RECORDING](#).

MAC is the unique hardware identifier for the network interface on the V400.

3.3.3 GPS



The GPS menu is the setup menu for the Global Positioning System serial connection.

The V400 can receive GPS data through the serial port and embed the data into recorded images. GPS data includes positioning and speed, and users can optionally turn these on or off. When turned on, the data will be recorded with each image.

If the user decides not to embed GPS data then it will not appear on the screen during playback in [PCLink](#). However the data is still included in the XBA files, therefore the speed dials will still operate in [PCLink](#).

The V400 is compatible with the standard NMEA-0183 GPS protocol. A suitable GPS serial unit can be wired to the V400 (see [diagram](#)).

EMBED GPS POSITION – When set to YES will embed the position information in recorded images.

EMBED GPS SPEED – When set to YES will embed the speed information in recorded images.

SPEED UNITS can be set for miles per hour (MPH) or kilometres per hour (KPH).

SYNC CLOCK WITH GPS - The V400 can be configured to synchronize the clock with the data and time information received from the GPS unit. When set to YES the V400 will synchronize the clock on power up.

GMT OFFSET - the GPS uses GMT time. If the unit is not in the GMT zone, a GMT OFFFSET is required in order to give the correct time zone for the location of the unit. Select + or – and the number of hours.

GPS BAUD – sets the baud rate at which the V400 will communicate with the GPS.

NB: When the baud rate is changed, it may be necessary to reboot the V400 in order that it can detect the GPS unit.

SPEED ALARM – selects the speed limit threshold at which the GPS speed alarm is triggered (see [ALARM OUTPUTS](#)).

STATUS – indicates whether or not a GPS unit has been detected. The status will be DISCONNECTED if not unit is detected or TRACKING SATELLITES if connected but no GPS lock has been established yet. If CONNECTED, GPS data/coordinates will appear.

3.3.4 GSM / Remote



The GSM/REMOTE menu configures settings for the serial port to either communicate with a GSM modem or other external equipment. The V400 supports a token-based command structure so that it can be integrated and controlled by 3rd party applications. See [RS232 EXTERNAL CONTROL](#) section of the manual.

RS232 - GSM CONTROL or [BRIDGE ALERT](#) can be selected. A selection of data rates are available; 2400bps, 4800, 9600, 14400, 19200, 38400, 57600, 115200bps.

GSM MODEM CONTROL - port is set to send/receive data to a modem.

[SMS MESSAGES](#) - SMS messages can be setup and triggered by the V400.

[HEALTH OVER SMS](#) - will send the V400 health status

[VIEW STATUS](#) - gives statistics of SMS messages sent and received.

RESET MODEM – will clear the modem statistics and send a modem reset command to the GSM modem.

MODEM LOOPBACK TEST – with a special test plug fitted on the modem port, it is possible to LOOPBACK test and confirm the hardware is functional.

X200 COMPATIBILITY MODE – this option is only for use by customers still using third-party external equipment originally designed for use with the Timespace X200 DVR.

3.3.4.1 SMS Messages



The SMS MESSAGES menu sets up how SMS messages are set up and triggered by the V400. Six different SMS messages can be configured with different text and recipients. Four lines of text can be inputted and additionally GPS location and speed can be included in the SMS.

[EDIT MESSAGES](#) – configures the SMS messages.

SEND SMS – allows the user to select when to send an SMS message;

NEVER	- Never.
MONTHLY	- On the 1st of every month (at midnight).
WEEKLY	- Every Monday (at midnight)
DAILY	- At midnight every day.
POWER UP	- When the V400 powers up

This may be useful as a test to confirm the V400/Modem is still on and functioning. It is also useful to keep alive a prepaid SIM card as some cards may timeout due to inactivity (subject to mobile operator rules).

USING – allows the user to select which one of six SMS messages is to be sent. Messages are set up in [EDIT SMS MESSAGES](#).

SEND SMS NOW - tests the GSM/SMS connection by sending a message using one of the six configured messages.

CONFIGURE ALARM INPUTS – allows the user to set up SMS messages as [ALARM INPUTS](#).

3.3.4.2 Edit SMS Messages

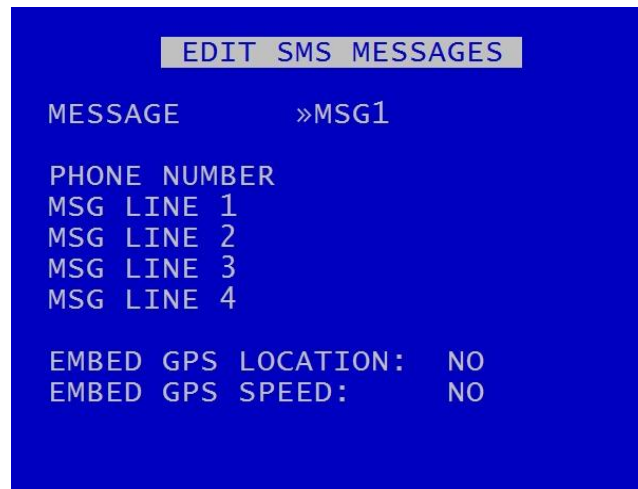

EDIT SMS MESSAGES menu allows the user to configure six different messages configured with different text and recipients.

MESSAGE – shows which of the six available SMS messages is currently being configured.

PHONE NUMBER – allows the user to insert the number of the phone for receiving SMS messages.

MSG LINE 1-4 – allows the user to insert text into the body of the SMS messages. Text and Number Input is via the keys on the [Reviewer](#).

EMBED GPS LOCATION and EMBED GPS SPEED – allows the user to select whether GPS location and speed are added to the SMS messages.

3.3.4.3 Health Over SMS



HEALTH OVER SMS menu will send the V400 health status including recording state, last recorded file, camera status/faults, disk service conditions, GPS location and serial number.

The feature can be setup to send an SMS at a scheduled time or if queried by an incoming SMS. The incoming SMS must only include the words "SEND SMS NOW" and will then send an outgoing SMS to the phone number as configured in the menu settings.

PHONE NUMBER - Mobile number to send SMS health message to.

SEND SMS selects when to send an SMS message. Select between NEVER, AT DAILY TIME and POWER UP.

DAILY TIME - Specify the daily time the SMS message is to be sent when AT DAILY TIME is selected on the menu. Times are input using the Text and Number Input keys on the [Reviewer](#).

INCLUDE IN SMS – Allows the user to include Camera Text and/or Filename Text in the SMS message. Select YES/NO.

SEND SMS NOW - Send a health message to the phone number specified now.

LAST REQUEST – provides details on timing of last request.

NB: The SEND SMS NOW option cannot be invoked if connected to the V400 via RemoteLink using the GSM modem connection. If this option is invoked, the RemoteLink connection will be dropped and no SMS will be sent.

The Health SMS message contains:

1. Type or reason for health SMS
2. Sending unit info
3. GPS info
4. Camera info
5. Time info
6. LED info
7. Service log info (which may be related to service/fail LED):

See [APPENDIX 10](#) – HEALTH SMS MESSAGE FORMAT for further details on how to read the messages and integrate with other systems.

3.3.4.4 GSM Status



The screenshot shows a blue background with white text. At the top, the title 'GSM STATUS' is displayed in a grey box. Below the title, the following statistics are listed:

CALLS	RECV	000
	SMS	HEALTH
RECV	000	000
SENT	000	000
ERRORS	000	000
LAST SENT		
SMS		NOT KNOWN
HEALTH	SMS	NOT KNOWN

GSM STATUS gives statistics of SMS messages sent/received as well as calls and image transfers.

Using the [RESET MODEM](#) function on the [GSM/REMOTE](#) menu will clear the statistics and send a modem reset command to the GSM modem.

3.3.5 PTZ Cameras

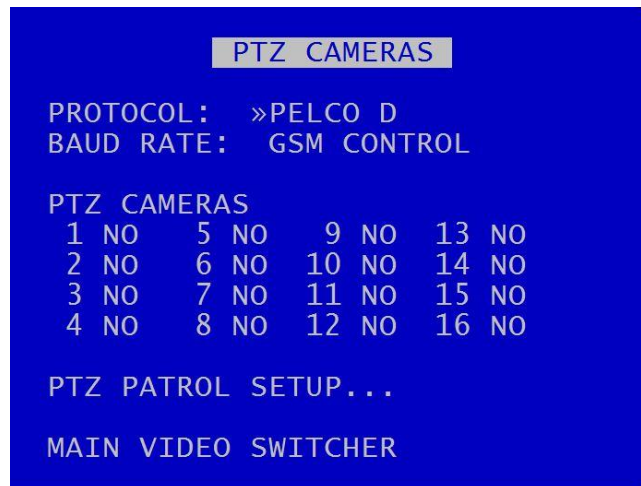

PTZ CAMERAS menu allows control over a Pan, Tilt, Zoom camera when connected to the V400's serial port. An RS232-to-RS485 convertor will be required – example convertor; [EXTERNAL LINK](#), Farnell code; 1683075.

Supported PTZ protocols are;

- Pelco D
- Pelco P
- Visca (Sony)

BAUD RATE – A selection of baud rates are available for the cameras: 2400bps, 4800, 9600, 14400, 19200, 38400, 57600, 115200. This baud rate setting is linked to the baud rate under the [GSM / REMOTE SETTINGS](#) menu. Only one of GSM or PTZ can be used at a time. Please refer to the Camera manufactures instructions on how to configure the camera baud rate.

PTZ CAMERAS – the V400 can support multiple PTZ cameras assuming that they are all the same protocol and baud rate. PTZ has its own addressing system. Set each required PTZ camera to YES. The PTZ mode will enable PTZ controls and functions using the [Reviewer](#).

[PTZ PATROL SETUP](#) – menu configures the PTZ cameras.

[MAIN VIDEO SWITCHER](#) – provides a link to the MAIN VIDEO SWITCHER for configuring camera dwell times etc.

3.3.5.1 PTZ Patrol Setup

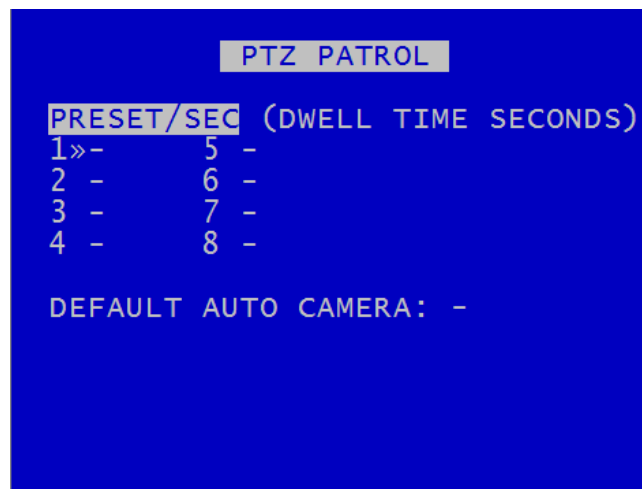

The PTZ PATROL menu configures the PTZ cameras to switch between preset positions as set by the user. This is similar to setting up the [Main Video Switcher](#).

The main PTZ are functions are to move the camera Left, Right, Up, Down, Zoom in and Zoom out. There are advanced features for setting up focus behaviour and additionally the V400 can access the cameras internal menus (if the camera supports it).

The V400 can also store 8 different user defined camera positions, for example preset position 1 could be a scene view overlooking a car park, preset position 2 could be zoomed in close to the entrance, preset position 3 could be pointed at the exit. The presets can be accessed by pressing the number keys on the [Reviewer](#) for quick panning to locations. The presets can also be triggered via [ALARM INPUTS](#).

NB: Some PTZ cameras will self enumerate in terms of PTZ addressing, some require physically setting using dip-switches (see manufactures instructions for details). You must connect the camera to the same DVR channel number as the PTZ addressing. If not, the controls within [PCLink](#) and the [Reviewer](#) may be associated with different connected cameras. If you are connecting self addressing PTZ cameras, they should be connected consecutively starting on channel 1.

DEFAULT AUTO CAMERA – if the switcher is not being used, select the PTZ camera number to show as default on start-up. **NB:** this setting initially takes priority over the switcher, unless or until the switcher is activated.

NB: PTZ cameras are controlled using the keys on the [Reviewer](#).

3.3.6 IBUS

```
IBUS
IBUS ENABLED:  »NO
LOCAL (LAN2)
IP ADDRESS:    192.168. 10. 30
REMOTE IP ADDR: 192.168. 10. 20
PORT:         22000
APPLY IP SETTINGS ABOVE
SET DEFAULTS
IBUS DEBUG:    NO
IBUS MESSAGE QUERY: 01
SEND MESSAGE QUERY NOW
```

Timespace has developed a diagnostic interface in conjunction with Transport for London (TFL) to monitor the status, performance and health of Timespace X200, X300, V400 and V500 digital video recorders on London Buses.

IBUS menu Details are found in [Appendix 8](#).

NB: IP address settings cannot be changed while recording is in progress – a warning will be displayed. Stop recording and amend settings as required before recommencing recording.

3.3.7 Bridge Alert



The Timespace BRIDGE ALERT is an early warning system to notify the driver of any low bridges near the vehicle. Bridge Alert is a driver aid, not a safety device.

The BRIDGE ALERT WARNING SYSTEM menu page enables BRIDGE ALERT and configures its settings.

BAUD RATE – will display either BRIDGE ALERT, GSM CONTROL, 2400, 4800, 9600, 14400, 19200, 38400, 57600, or 115200bps. This setting will match that configured in the [GSM/REMOTE](#) menu.

BRIDGE ALERT ENABLED – select YES/NO

VEHICLE HEIGHT – set the height of the vehicle (to a maximum of 10m). Use the left/right Menu Navigation keys on the [Reviewer](#) to increase/decrease the vehicle height.

Bridge Alert has 3 different stages of warning: FIRST WARNING, SECOND WARNING, DANGER WARNING. The user can set:

1. First warning distance (off by default)
2. Second warning distance (200m by default)
3. Danger warning distance (<30m by default)

NB: FIRST and SECOND WARNING will output once each.

DANGER WARNING will output continuously until the vehicle moves away from the low bridge, or until the warning is silenced via the controller switch on the [Bridge Alert unit](#).

DISTANCE – Bridge Alert will activate when the vehicle is the selected distance from the low bridge.

1. First warning distance options: 600m, 500, 400, 350, 300, 250, 200, 150, 120, 100m, OFF.
2. Second warning distance options: 400m, 300, 250, 200, 150, 120, 100, 80, 60m, OFF.
3. Danger warning distance options: 100m, 80, 60, 50, 40, 30m.

Due to GPS inaccuracy, the Bridge Alert data uses a safety tolerance of 60m (was 120m in V400 V1.7.3 software and before). This 60m safety tolerance is 30m database accuracy and 30m bus GPS accuracy added together. This is then added to the default distance options so that the default voice warning message/beep is at:

1. first warning distance – off by default (+ 60m if it was used)
2. second warning distance – 200m by default + 60m = 260m
3. danger warning distance < 30m by default + 60m = 90m

Options for warning sounds are:

NO SOUND – No audio. LEDs flash only when activated.

JUST BEEP – 4 beeps with flashing LEDs when activated.

JUST VOICE – LEDs flash followed by voice message stating the distance to the low bridge.

BEEP AND VOICE – 4 beeps with flashing LEDs followed by voice message.

VISUAL WARNING – this provides the option to display information on the driver monitor when Bridge Alert has been activated.

WHEN IGN OFF – provides an option to ENABLE or DISABLE Bridge Alert audio when the vehicle's ignition is off. This may be selected eg when a vehicle's waiting area, eg bus stop or bus station, is in close proximity to a bridge. It may be considered desirable to have the Bridge Alert audible warning disabled during the vehicle's waiting time, ie the period when ignition is off.

NB: The default setting is ENABLE AUDIO.

Bridge Alert volume can also be adjusted in AUDIO RECORDING > [AUDIO ADVANCED](#) > LINE OUT VOLUME.

CONTROLLER – shows the status of Bridge Alert:

DISCONNECTED – No Bridge Alert controller is present

CONNECTING – Bridge Alert controller is present and is communicating with the V400.

CONNECTED – NO GPS – Bridge Alert is present, but there is no GPS signal

CONNECTED – GPS OK – Bridge Alert is present and there is a GPS signal. A green LED will be present on the Bridge Alert controller.



Figure 4 Bridge Alert Control Unit

3.3.8 CANLink

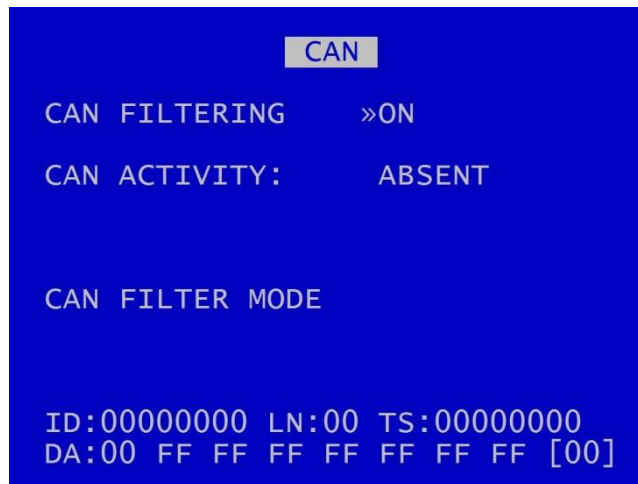

Timespace has developed a vehicle CAN (Controller Area Network) reporting system. A secure CAN interface enables the DVR to record CAN data and download vehicle CAN information via the vehicle depot's Wifi/LANLink system.

The CAN menu screen shows CAN activity as either ABSENT or DETECTED. This is useful for diagnosing connection issues.

CAN FILTERING can be selected to be OFF or ON. When filtering is turned ON, only a subset of messages is recorded. These are mainly FMS, bus, truck and other J1939* messages. With filtering OFF, all CAN messages are recorded.

The default is for CAN filtering to be ON when the V400 is rebooted or powered up.

When CAN is active, the digits at the bottom of the menu screen will change to show that CAN is being captured.

*Society of Automotive Engineers standard SAE J1939 is the vehicle bus recommended practice used for communication and diagnostics among vehicle components.

3.4 Advanced Menu

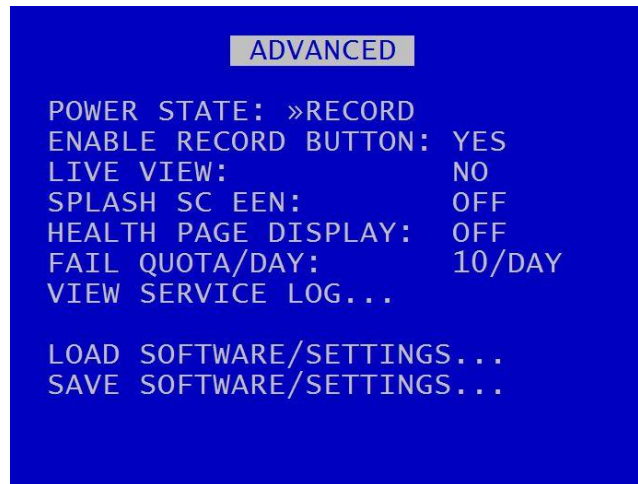

ADVANCED menu contains advanced options that normally do not need to be edited after installation.

POWER STATE – Set if the V400 will RECORD, DO NOT RECORD or USE LAST STATE. If use last state is selected the unit will record on power up if it was recording when power was disconnected. If it was not recording when power was disconnected, it will return to this state on power up.

ENABLE RECORD BUTTON – controls whether the record button on the [front panel](#) of the V400 DVR can be used to start and stop recording (enable/disable).

LIVE VIEW – if set to YES, live view of camera will be displayed even if the disk cartridge is removed. If set to NO and the cartridge is not present, the initialisation screen is shown and a reboot will follow.

SPLASH SCREEN controls the length of time an operator logo will be displayed. A .bmp file can be loaded / displayed on boot up. The .bmp must be in a specific format and copied onto the cartridge. See [Appendix 7 – Splash Screen](#) for further details.

HEALTH PAGE DISPLAY – controls the length of time the unit health status will be displayed for on boot up

FAIL QUOTA/DAY – sets how many fail messages that must occur for any given day before the FAIL LED is lit. During normal operation it may be acceptable to receive a certain number of fail events before action is required. Set as applicable. Available options are NEVER, 1/DAY, 2, 5, 10, 20, 50/DAY.

[VIEW SERVICE LOG](#) – displays any service messages that have been logged by the system.

[LOAD SOFTWARE/SETTINGS](#) – provides options for loading new/upgraded software and/or settings.

[SAVE SOFTWARE/SETTINGS](#) – provides options for saving the current settings.

3.4.1 Health Page Display

HEALTH PAGE DISPLAY controls the length of time the unit health status will be displayed for on boot up. The health page includes a simple traffic light status and may include service/fail code conditions as well as the current recording state. The health page can also be activated via an alarm input.



3.4.2 Service Log



VIEW SERVICE LOG – displays any service messages that have been logged by the system.

Messages can be scrolled through and reviewed. Details of date/time and service/fail codes are shown.

[RESET SERVICE LOG](#) – clears the service log.

WRITE LOG TO – select from HD or SD. The screen will show **DONE** when this is complete.

NB: when saved to the HD/SD, the log files are encrypted but can be sent to Timespace for analysis if required. Contact support@tspace.co.uk for further information.

3.4.2.1 Reset Service Log



SERVICE LOG RESET menu – clears any service log messages.

Press the right arrow key, and then again to confirm.

HINT: Clearing the service log will clear the front panel service/fail LEDs.

3.4.3 Load Software/Settings



LOAD SOFTWARE/SETTINGS menu provides options for loading new/upgraded software and/or settings. An .XOS file should be copied onto the cartridge or SD card using a PC then inserted into the V400. Settings can also be copied from another V400 unit.

NB: Future releases of V400 software will also allow automatic updating of DVR software via SD card without requiring a [Reviewer](#) to access the DVR menu system. See [Software](#) for further details.

LOAD FROM – select HD (to load from the hard disk drive) or SD (to load from the SD card).

LOAD SYSTEM SOFTWARE – select from the options to load software either:

WITH FACTORY SETTING (load the XOS software with Timespace factory default settings).

WITH CURRENT SETTINGS (load the XOS software but retain settings as installed in the currently configured DVR).

WITH XOS SETTINGS (load the XOS software with settings from the HD cartridge or an SD card).

LOAD MENU SETTINGS – used to copy menu settings from another DVR unit and replicate these on the second DVR.

LOAD CONFIG DATA – load eg settings for a new IP Camera via a TSCONFIG file. See IP Camera [TYPE SETTINGS](#) menu for more information.

WARNING: Caution should be taken to ensure that power is not lost during an upgrade.

3.4.4 Save Software/Settings



SAVE SOFTWARE/SETTINGS provides options for saving the current settings. The current software and settings will be written to the HD cartridge or SD card.

Select SAVE TO: HD to save to the hard disk drive, or SD to save to the SD card.

SAVE SYSTEM SOFTWARE – save the .XOS file.

SAVE MENU SETTINGS – save menu settings to transfer to another unit. NB: it is possible to save the menu settings and remove parts not required, retaining only the small section which includes the required settings.

SAVE CONFIG DATA – save the CONFIG data on to either the selected HD or SD card.

4. System Information And Security

4.1 Language Selection

By default the V400 menu system is displayed in the English language.

Timespace Technology can provide a language template file which the user can translate and return to Timespace Technology for incorporation into the V400 software. This will allow all text displayed on the [Reviewer](#) to be in the users preferred language.

Language is selected in the SYSTEM SETTINGS > RESET menu. The V400 needs to be rebooted before the new language settings will take effect.

4.2 Video Standard – PAL and NTSC

The V400 offers the ability to switch between the different video standards, PAL and NTSC.

PAL (Phase Alternating Line) is the standard used in most European countries with the exception of France. The V400, when configured to use PAL, offers a maximum capture rate of 25 fields per second (per channel).

NTSC (*National Television Standards Committee*) is the standard used in the United States of America. The V400, when configured to use NTSC, offers a maximum capture rate of 30 fields per second (per channel).

Note that if the unit is configured for PAL and an attempt is made to play back NTSC recordings, the image will appear vertically 'squashed'. Similarly, if the unit is configured for NTSC and an attempt is made to playback PAL recordings, the image will be clipped.

4.3 File System

The V400 uses a proprietary file type with the file extension .XBA. Images from multiple cameras along with audio, GPS and other meta data are stored in these files. The V400 stores XBA files on the cartridge in a loop over the physical disk and does not use a fragmented file structure. The V400 uses a linking mechanism (FAT area) for PC compatibility. This compatibility conforms to the Microsoft standard FAT32 file system that is compatible on all PCs and many other systems.

Two types of File System behaviour are available on the V400; Loop and Single Pass.

Loop Recording

The V400 will automatically delete the oldest recordings first when the Hard Disk Cartridge is full (with the exception of write-protected files). Write-protection can be used to keep Alarm recordings but loop the background (Normal) recording.

Single Pass Recording

The V400 records until the Hard Disk Cartridge is full and then stops.

Recordings may be deleted in the SETTINGS > SYSTEM SETTINGS > RESET menu or loop recording enabled so that the oldest files will be overwritten first. The File System Recording Mode is set in the SETTINGS > SYSTEM SETTINGS > FILE SYSTEM menu.

HD buffer recording

The DVR buffers recording for up to 10 seconds before committing to the hard disk in order to improve reliability during high G-force events. This feature is available from V400 software Version 1.6.0 onwards.

4.4 Video Compression

The V400 records images, audio, GPS and other meta data into 1 Minute, 5 minute, 10 minute or 1 hour proprietary format files ending with the .XBA file extension. For security and optimisation reasons .xba files can only be viewed on a PC using the proprietary PCLink software or authorised Timespace partner software.

The images are compressed using **H264** video compression giving best of class quality and lowest image size. H264 is by its nature a predictive compression scheme meaning old images are used to predict future images. Every 2 seconds a new keyframe is recorded (an unpredicted image that stands on its own) and the remaining 2 seconds worth of images are predicted from this and from each other. The images can be searched easily with a granularity of 2 seconds (using the key frame) during playback.

A trade-off between image quality and file size can be made by selecting different levels of video quality on the V400: low, medium, high, v.high, v.v.high and super. The low setting uses greater compression than the higher settings and consequently less disk space is used.

As image quality rises however so does the resultant file size so a decision has to be made as to the level of image quality needed and the length of recording required to be stored on any given size of Hard Disk Cartridge. The V400 uses a constant bit-rate scheme so every image has a constant average size in bits relating to the quality setting. The following table lists the qualities and the corresponding kbits per image that results:

Super	200kbits per image	
VV.High	140kbits per image	
V.High	100kbits per image	← Transport for London approved quality
High	70kbits per image	
Medium	50kbits per image	
Low	35kbits per image	

An example duration of recording is easy to calculate:

1TByte disk, 10 images per second, V. High Quality
 $1,000,000,000 \text{ kBytes} / (3600 \text{ seconds per hour} \times 10 \text{ IPS} \times 100 \text{ kbits per image} / 8 \text{ bits per byte})$
 $= 1,000,000,000 / 450,000$
 $= 2222 \text{ hours or } \underline{92 \text{ days}}$

The V400 records in 2CIF Frame Resolution 720 x 288 (pixels).

The V400 provides an on-screen calculator during setup when using the [Reviewer](#). It shows how long the recordings will last before they are overwritten. This is based on the current quality, images per second settings and the installed cartridge size.

4.5 Audio

The V400 has two mic level audio inputs and two line level output channels via a 6 pin Molex connector.

The two input channels record in Stereo and can be assigned to different recording modes e.g. Normal Record, Timer Record, Alarm Record and SD Record. The audio channels can be played back individually or together when viewing footage in PCLink PC software. They can also be disabled during playback.

The V400 has a built in microphone pre-amp. This amplifies the microphone signal by 100 times. The gain of the audio input (post pre-amp) is also adjustable in the menu from 0.125V RMS to 2V RMS. This equates to a microphone levels of 1.25mV RMS to 20mV RMS.

Menu setting	Microphone sensitivity (full scale)
0.125V RMS	1.25mV RM
0.25V RMS	2.5V RMS
0.5V RMS	5V RMS
1.0V RMS	10V RMS
2V RMS	20V RMS

The microphone is also phantom powered at a voltage of 2.7V making it suitable for use with most electret or electret/condenser microphones including a wide range of small microphone cartridges

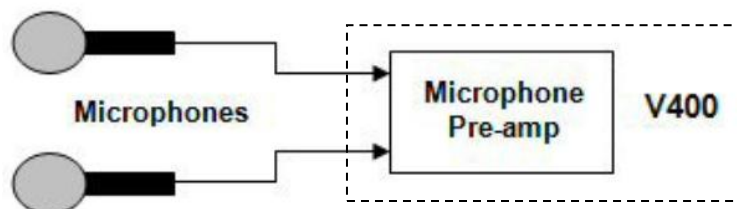

Figure 5 - Microphones

The audio sampling resolution determines the amount of noise in a system. The V400's 16 bit sampling resolution is C.D. quality with imperceptible noise, as long as the user sets the recording level to the maximum possible (without clipping) to use the full dynamic range.

If [wiring a line-level microphone](#), click on the link for further instructions.

4.6 PC Access Precautions

The V400 file system uses a standard FAT32 file system so that a PC can read the contents. The PC will access the cartridges in a different way to the V400. The V400 will not be able to read every FAT32 file system written by the PC and it is therefore important to restrict what the PC does to the file system.

Permitted on a PC

- Reading the .xba files
- Modifying the write-protect status of files
- Performing disk utilities that read the disk (e.g. Scandisk) but do not modify disk

Not Permitted on a PC

All write accesses to the disk if it is to be reused in an V400. These include:

- Formatting the disk on PC (including any Disk Manager MBR checks/fixes)
- Defragmenting the disk
- Deleting files
- Renaming files
- Generating new files
- Creating a recycle bin on the disk

NB: if any of the above non permitted actions are used, the cartridge will need to be reformatted on the V400 using the [Reviewer](#). This will erase all data on the cartridge and format it correctly for further use in the V400.

4.7 PC Network Access

The V400 can be accessed through a number of PCLink Suite Applications, included in the USB Kit. Files can be downloaded, images viewed, V400 controlled and settings adjusted over LAN.

Each feature runs over the LAN using a specific protocol and on a specific network port.

Security measures on a network such as Firewalls, encryption and MAC address filtering may need to be adjusted in order to achieve this. Security applications such as Norton and Symantec on the PC may need to be configured to allow the PCLink Suite applications to operate correctly. Any installed network or local PC firewalls (including Windows Firewall) may have to be instructed to allow the use of these ports to communication between the PC and the V400.

Ports:

Port	Protocol	Function	Used By	DVR	Description
7	UDP	Echo	LANLink / PCLink	All	Unit discovery
21	TCP	FTP	LANLink	All except X200	File download
23	TCP	Telnet	PCLink	All	Unit commands
69	UDP	TFTP	LANLink / PCLink	X200 only	File download
2055-2058	TCP	Custom	PCLink	All except X200	Live video and menu
5465-5468	UDP	Custom	PCLink/RemoteLink	X200 only	Live video and menu

Figure 6 – PC network access ports

4.8 Watermark and Sequencing

4.8.1 Watermark

The V400 uses a fragile watermark. Any modification to the recorded file will destroy the watermark.

The image, audio and ancillary (meta) data that makes up the recorded file is passed through a function that generates a "magic number" or hash code from the data. A hash code is created automatically by the V400 every $\frac{1}{4}$ of a second for each $\frac{1}{4}$ second of data. Each hash is then passed through an encryption function and then stored in the file.

A sequencing number ensures that all hash codes and corresponding data are present and where multiple files exist that no files are missing.

To check that a number of files have not been altered or modified in any way, the watermark checking program (e.g. PCLink) recalculates the encrypted hashes (watermarks) and checks these against the watermarks provided in the file. If all the watermarks match the recorded file has not been tampered with. The watermark is "destroyed" when the encrypted hash code stored in the file and the encrypted hash code of the data do not match. PCLink produces a report which can be used in court to validate recorded files.

The watermark is always on the V400 i.e. all recordings have the watermark embedded in real-time as the footage is laid to disk, it cannot be turned off. Within PCLink, you can generate a report for a number of files. You can also select a file for watermark checking.

Encryption type;

- Hashing function: SHA256
- Encryption function: AES256

4.8.2 Sequencing

In addition to every $\frac{1}{4}$ second being protected by a Watermark, each watermark has its own unique sequence number. This protects any images being removed from a file and protects any files being removed from a sequence of files.

4.8.3 Watermark / Sequencing Report

Within [PCLink](#), a report can be produced against an image, file and/or sequence of files.

PCLink will analyse the data against the encrypted hash and analyse the data's sequence numbering. If any images have been modified, any images removed or any files removed, PCLink will identify them and report accordingly.

Files fail if:

- Any video/audio/meta data frame (other than the last in a non-closed file) had an invalid watermark
- Video/audio/meta frames were missing or out of sequence (in newly generated files)
- Files passed to the checker were not in sequence (in newly generated files)
- Files are missing their sequence frame (in newly generated files) in properly closed files.
- Time Adjust TCP port 8463 (can be configured within the V400 menu system).

5. System Interfaces

5.1 GPS

The Global Positioning System (GPS) is a worldwide radio-navigation system able to calculate position using triangulation based upon satellite signals. The GPS must be positioned so its antennae have a clear line of sight of the sky – obstructions such as foliage and reflected signals in built-up areas can reduce the accuracy.

The V400 can be fed GPS data and embed coordinates into images for location identification and real-time mapping playback in PCLink.

The V400 uses the NMEA-0183 Interface Standard. GPS data is received into the V400 GPS port using a single serial data line.

The V400 has been tested with the following GPS receivers:

- Garmin GPS16 LVS & GPS18 LVC & GPS18x LVC
- Byonics GPS2 - [EXTERNAL LINK](#)
- RoyalTek Sapphire Serial GPSr
- Fortuna U2 Smart GPS

NB: When using the Garmin GPS18 LVC the V400 baud rate must be set to 192,00.

Connection

The GPS receiver is connected to V400 through the 18 way Molex connector. Pin 17 is used by the V400 to receive GPS data. The V400 can provide +5V or 12V power to the GPS mouse on the 18 way Molex connector.

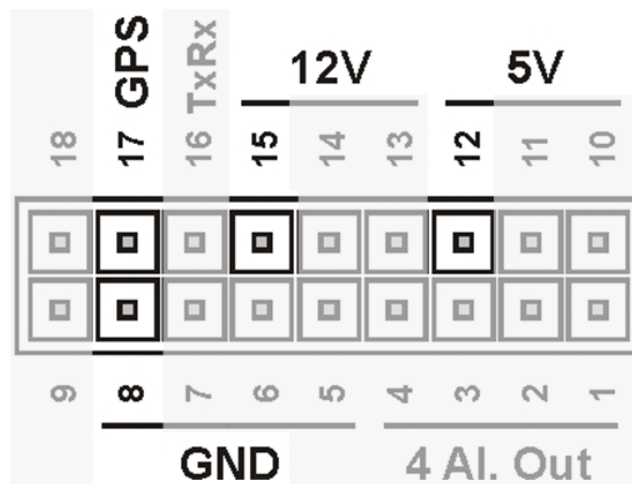

Figure 7 GPS Connection

Options

The V400 GPS menu options allow the embedding of GPS position and speed, assuming a valid GPS signal is being received and the data passed correctly to the V400.

If a GPS receiver is connected but satellite lock has been lost then it is still possible to record the data but it will not indicate position, speed, date or time and the actual content may vary according to the type of GPS receiver employed.

The V400 Digital Video Recorder includes a clock which is used to timestamp recording files and overlay the date and time on recorded images. Although accurate, the V400 can be configured to synchronize the clock with the date and time information received from the GPS receiver.

When a GPS unit is plugged into the V400, and it has locked onto the satellites it then sends GPS time and position and other data every second. If after 10 seconds the V400's internal clock is consistently +/- 2 seconds compared to the GPS unit then the time error is noted. On the next power cycle the time error is corrected.

Local Standard Time - The time received from the GPS receiver is always UTC (Coordinated Universal Time) which is the same as GMT (Greenwich Mean Time). In order to correctly work out the error between the local standard time (used by the V400's internal clock) and that received from the GPS receiver, the system must be set with the correct time zone offset.

GPS Baud Rate - Set the V400 data rate according to the GPS mouse you are using. Rates configurable include; 2400, 4800, 9600 and 19200, 38400 bps.

NB: It may be necessary to change the baud rate on the GPS mouse and set it to a specific rate in line with the V400 setting. Reference the GPS mouse product instructions to configure the baud rate then power off/on the V400 (whilst connected to the GPS).

5.2 Remote Operation (GSM / LAN / Wifi / 3G/4G) – Telnet / FTP

The V400 system provides a number of interfaces to remotely control and configure the recorder as well as reviewing recorded footage and displaying live camera views.

A **GSM** modem can be connected to the **Serial** port on the V400 and used to dial in to the V400 to view live camera images and configure the V400 menu settings. **SMS** messages can be configured to send texts alerts for example on an Alarm input. SMS messages can also be configured to send the system Health update upon power up or configured time.

The V400 has a comprehensive set of **RS232** control commands that run over the **Serial** port. This open architecture allows full integration with third party hardware/software. Please refer to the [RS232 Control](#) section of this manual for details on RS232 external control of the V400.

In addition to the RS232 support, the V400 provides a **Telnet** interface over TCP/IP. The same command set detailed in the RS232 section can be used over Remote Live View using the Telnet protocol.

A simple test to check connectivity between PC and V400 you can try following with a Telnet client (e.g. Putty, Termit);

- Telnet (port 23) to 10.0.0.200 (default V400 IP)
- Enter the username; user01
- Enter the password; PASS01
- Type **#HANDSHAKE**; you should receive **OK**.

The V400 supports **FTP** over TCP/IP using the LAN socket. The V400 FTP server allows video files to be downloaded using either a hard-wired, wireless or 3/4G IP connection. A web browser can be used to FTP onto the V400 by typing the following in the address bar;

<ftp://user01@10.0.0.200/> (default IP). This will prompt for the password.

<ftp://user01:PASS01@10.0.0.200/>(default IP). This will log straight in.

Supported browsers are: Microsoft **Internet Explorer**, Mozilla **FireFox** and Google **Chrome**. A third party FTP client can also be used, for example **FileZilla**.

PCLink Remote features include; Live View, Playback, Configuration. A brief overview of the applications included in PCLink Suite can be found on the PCLink Suite page of this manual. For detailed application instructions, see the separate PCLink Suite manual available here; www.tspace.co.uk.

5.3 RS232 / TELNET External Control

The V400 software includes external control via RS232 (side panel connector) or via Telnet over Remote Live View and provides functions:

- Files can be created and written into on the V400 hard drive. The files can also be read back.
- The V400 can be controlled via Commands. This allows many displays and recording functions to be carried out by an external device.

These two features are enabled under the SETTINGS > EXTERNAL EQUIPMENT > GSM / REMOTE SETTINGS menu by changing the RS232 setting to a BAUD RATE e.g. 115,200.

Baud rates of 2400, 4800, 9600, 14400, 19200, 38400, 57600, 115200 can be selected. The external commands operate over the RS232 port. This port is also used for GSM modem control. GSM control cannot be performed at the same time as external control.

Connect the V400 RS232 port to a PC using a bespoke cable.

5.4 USB Interface Kit

The purchase of the Timespace USB Kit or cartridge station includes the necessary licence for use of PCLink Suite software including free of charge updates on a single PC (reasonable use policy allows installation on a secondary portable PC; laptop). Timespace Technology does not authorise the unlicensed usage of PCLink Suite software.

The USB Kit provides all hardware and software necessary to review and archive recordings on a PC from a Hard Disk Cartridge when it has been removed from the V400 Digital Recorder. No additional device drivers are required for the USB Interface Kit when using Windows 2000, XP, Vista, Windows 7 or Windows 10.

Kit Contents:

- 1x USB / IDE Interface Lead
- 1x PCLink Software CD

Connecting to a PC using the USB Interface Kit

1. Remove the Hard Disk Cartridge from the V400.
2. Plug the multi-pin D shaped IDE USB lead into the rear of the cartridge and then plug the smaller USB connector into an available USB port on the PC.

Once the disk has been connected, the PC should take a few seconds to detect the disk and Windows should automatically assign a drive letter to it. The drive should be viewable in Windows Explorer with .XBA files visible with their associated icon (assuming PCLink Suite is installed);



Recording files can now be viewed using PCLink;

- Individual files can be opened directly from Windows Explorer by double clicking.
- Up to 15 files can be opened by selecting them and using RIGHT CLICK > OPEN WITH PCLINK.
- .XBA files can be dragged from a Windows Explorer window and dropped onto the main area of the PCLink window.
- The entire cartridge can be loaded by opening PCLink and selecting the AUTOLOAD option.

A specific folder can be loaded from within PCLink; FILE menu, LOAD FOLDER

6. Installation Guide

6.1 Safety

The V400 meets the requirements of BS EN60950 (Safety Requirements of Information Technology Equipment).

The V400 is designed to be powered from an external power source which complies with the Low Voltage Directive (2014/35/EU).

The V400 has approval under UN ECE R118 fire safety regulations (burning behaviour of materials).

The V400 is designed for indoor use in the temperature range -10° to +50°C, 10% to 90% RH (non-condensing).

6.2 Environmental

The V400 may be operated in ambient temperatures from -10°C to +50°C. This specification applies in still air and ambient temperature measured 15cms above the centre of V400.

If the V400 is to be mounted in an enclosure it is important that the internal temperature inside the enclosure does not exceed the specification above and any new enclosure design should be tested.

6.2.1 Shock And Vibration

Consideration should be paid to the mounting position so that the levels of shock and vibration that may be encountered are minimized.

6.2.2 EMC

The V400 meets the requirements of the relevant European Union Directive on EMC relating to EMC emissions.

6.2.3 Recycling

When the product has reached its end of life and requires disposal, recycling instructions are available upon request.

6.3 Conformity

Conformity certificates and approvals are in [Appendix 6](#).

6.4 Warnings

- **The use of hard disk cartridges other than those supplied by Timespace Technology will invalidate the warranty of the V400 recorder and will constitute a breach of the V400 operating software copyright.**
- **The purchase of Timespace USB kit or cartridge station includes the necessary license for use of PCLink Suite software on one pc, including free of charge updates. Reasonable use allows a second installation on a portable computer provided both installations are not used simultaneously. Timespace Technology does not authorise the unlicensed usage of PCLink Suite software.**
- **The V400 recorder must always be mounted so that there is a free flow of air around it. If it is mounted in an enclosure, it is essential that adequate ventilation is provided, and it is recommended that a fan is incorporated in the enclosure design.**
- **Hard disk cartridges are sensitive to shock, vibration and humidity and must be used within operating temperature range as detailed in the V400 specification in the [Appendices](#).**
- **It is highly recommended that recording is stopped before power is removed from the V400 to avoid loss of data. It is also recommended to stop recording before the cartridge or SD card is removed.**
- **Cartridges should be safely removed from windows operating system environment prior to removing power/USB cable. Data loss or corruption may occur if this is not followed.**
- **Do not wet the product when cleaning.**
- **This product contains a lithium battery. Do not recharge, open, heat or dispose of in fire. Dispose of according to local regulations.**
- **V400 may become unusable if power to the unit is lost during a software upgrade.**

6.5 V400 Connections

6.5.1 V400 Front Panel



Figure 8 V400 Front Panel

REC (RECORD) BUTTON

TURNS configured recording mode on and off. Button can be disabled within menu settings.

LEDs

Power - Illuminated when the V400 is powered (Green LED).

Rec - Illuminated Red when the V400 is recording.

Disk - Pulses Green/Red when the V400 is reading/writing to/from the Cartridge. Solid Red indicates no disk is present / detected.

SD - Pulses Orange when the V400 is recording to the SD card.

Fail - Illuminated Red when any of the Fail conditions are met (refer to [Service / Fail](#) page).

Service - Illuminated Orange when any of the Service conditions are met (refer to [Service / Fail](#) page)

At Power On - All LEDs will illuminate whilst the V400 initialises and will remain lit during system check (menu disabled) until the unit is operational. Once operational only the Power LED will remain illuminated unless recording is taking place.

CARTRIDGE LOCK

- Locked - Securely locks the removable cartridge in place and enables it for use.
Unlocked - Turns off the cartridge lock, releasing the cartridge lock for removal.

SD CARD

The V400 supports a single SD card for configurable functions:

Dual Recording - The V400 menu settings can be configured to record up to 25 images per second to the SD card in addition to primary images per second being recorded to the cartridge.

NB: separate from this, the SD card can also be used for recording in [HD Mirror Mode](#). The 25IPS limit does not apply in [HD Mirror Mode](#).

File Download - Files that are recorded on the V400 Cartridge can be selected and copied to the SD card for review on a PC.

SD Compatibility The V400 supports **SanDisk SDHC** (Secure Digital High Capacity) cards **only**, up to 2TB capacity. Both 15 and 30MB/s SD cards are compatible however for best Audio playback results, 30MB/s is recommended.

6.5.2 Reviewer Connector

Connect the [Reviewer](#) to V400 Reviewer socket using a RJ45 cable.

Signals for this connector are as follows:

- 1 Video out
- 2 Video ground
- 3 Audio ground
- 4 RS232 Rx
- 5 RS232 Tx
- 6 Audio out (line level)
- 7 Power ground
- 8 12V

12V is supplied (regulated) to the [Reviewer](#) from the V400.

6.5.3 V400 Side Panel Interface /Connections

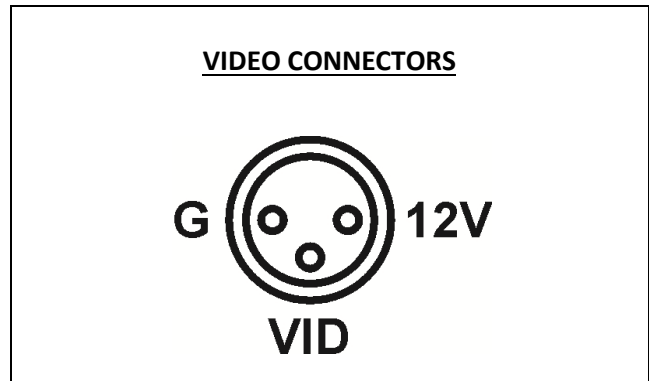
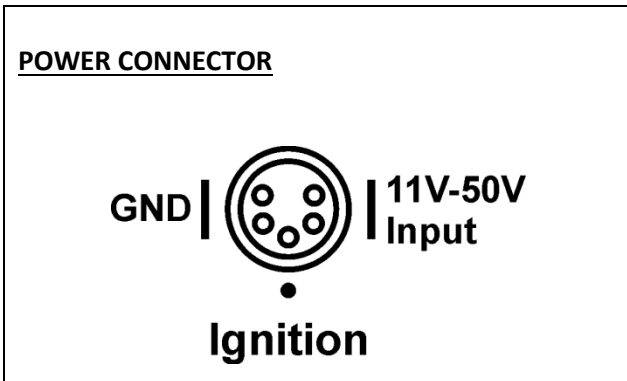

- POWER OUTPUTS**
- 5V – 2A resettable fuse, 4A trip (10W global across the three 5V outputs on the Molex).
 - 12V – 2A resettable fuse, 4A trip (24W global across the three 12V outputs on the Molex).
 - 16 Camera outputs – 0.2A resettable fuse, 0.4A trip (2.4W per channel).
 - Main video output – 12V 2A resettable fuse, 4A trip (24W)
 - Aux video output – 12V 2A resettable fuse, 4A trip (24W)

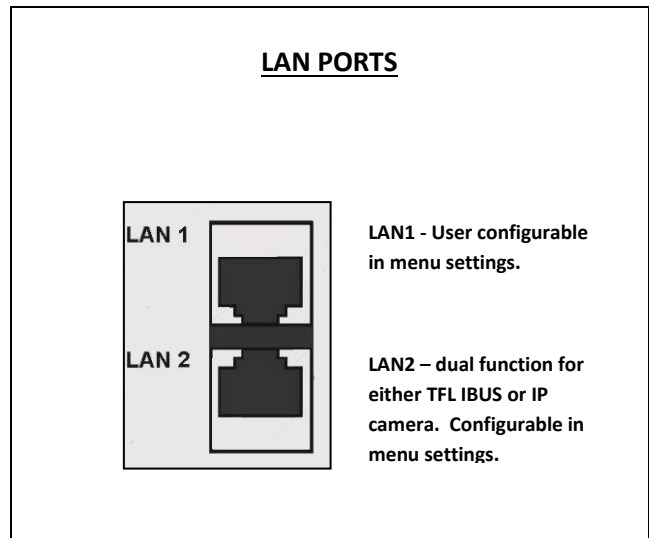

Figure 9 V400 Side Panel Interface/Connections

6.5.4 Main Out and Aux Out (Video Outputs)

Timespace recommends the use of ASC100 anti-surge cable with certain types of monitor. Please check your monitor’s technical specification for details.

When in place the ASC100 limits the surge current to a maximum of 6A at 12V for up to 20 milliseconds.

6.5.5 Camera connections

Timespace recommends the use of screened cables for camera installation. All in-house testing and independent external approvals of the V400 have been conducted using RG59 analogue camera cable, with an impedance of 75 Ohms.

6.5.6 Molex Side Panel Connectors

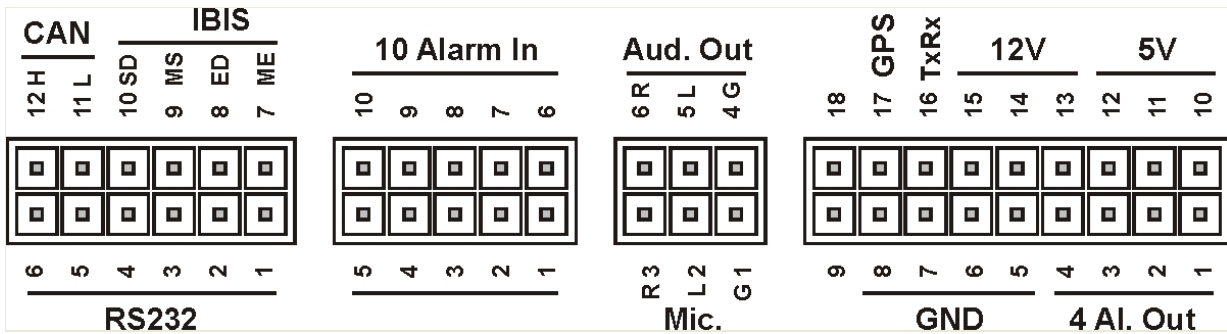

Figure 10 V400 Molex Side Panel Connectors

	PIN	Description	I/O	Type
RS232	1	DCD, Data Carrier Detect	<	Detect modem status
	2	RD, Receive Data	<	Serial data
	3	TD, Transmit Data	>	Serial data
	4	RTS, Request to Send	>	Handshaking
	5	CTS, Clear to Send	<	Handshaking
	6	GND, Ground		

IBIS	7	ME	WBEM-
	8	ED	WBED+
	9	MS	WBMS-
	10	SD	WBSD+
CAN	11	L	Low output
	12	H	High output
ALARM IN	1-10	0-30V input range, switching configurable <2, 2-24, >24V	
MIC / AUDIO OUT	1	GND, Ground	
	2	Left channel audio in	<
	3	Right channel audio in	<
	4	GND, Ground	
	5	Left channel audio out	>
	6	Right channel audio out	>
ALARM OUT	1-4	Active pull to GND, Ground	
GND	5-8	GND, Ground	
	9	No connection	
5V	10-12	+5V 2A resettable fuse (10W global across the three 5V outputs).	>
12V	13-15	+12V 2A resettable fuse (24W global across the three 12V outputs).	>
TxRx	16	Expansion pin	
GPS	17	RD Receive Data	<
	18	No connection	

< to V400

> from V400

6.5.7 Ethernet Connector

The V400 provides 2x RJ45 connectors;

LAN1 - User configurable standard network interface. Configurable IP address, Subnet and Gateway within the SETTINGS > EXTERNAL EQUIPMENT > LAN menu.

LAN2 – Dual function for Transport for London IBUS diagnostic interface and IP camera. Configurable IP address and Enable / Disable / Debug options. Proprietary interface; cannot be used for secondary LAN interface. See [IBUS](#) page for further information.

Connect via a standard RJ45 Remote Live View cable (straight i.e. pins 1-1, 2-2, 3-3 etc.) to Remote Live View hub, switch, router, wireless LAN adaptor or 3G modem.

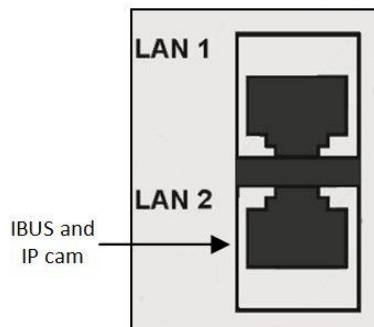

Figure 11 Ethernet Connector

Internal Connections: 1 Tx+, 2Tx-, 3 Rx+, 4 NC, 5 NC, 6 Rx-, 7 GND, 8 GND

NB: The IP camera is connected to the V400 DVR using a RJ45 cable CAT 5e or CAT 6 to LAN2 of the DVR. Please note that the V400 is not POE and therefore the IP camera needs to be powered externally, either from the V400 DVR or from another source.

Warning – if the input voltage to the V400 DVR goes below 12V, then the output voltage from the DVR will also be below 12V.

6.6 Installation Instructions

The V400 is designed to be mounted on its base plate; horizontally or vertically in any axis, but on a strict perpendicular angle. For wall mounting with the V400 horizontal, the right angle plate accessory must be used.

It is recommended to power the V400 via the two power input pins on the 5 pin XLR connector. For maximum reliability, Timespace recommends that the power feed should be split and wired to both pins. In addition, it is recommended to wire an ignition feed to ALARM1 on the Molex connector.

The V400's built-in [GSensor](#) must be configured during the installation process. Once the V400 is installed, the direction of the front and side panel must be set e.g. Front panel FORWARDS means the V400 front panel is facing the front of the vehicle, therefore the Connector Panel must be either LEFT, RIGHT, UP or DOWN depending on the mounting position. After configuring the V400 orientation, the [GSensor readings must be zeroed](#).

6.6.1 Proximity of other electrical equipment

Any electrical equipment located close to the DVR should be EMC-tested and comply with the relevant standards. Timespace recommends that aerials or high-powered electrical equipment should be located away from the DVR.

6.6.2 Installation Check List (Example)

REQUIRED / RECOMMENDED

- Mount the V400 in position on the base plate or right angle bracket
- Set the [GSENSOR](#) orientation (which way is the V400 mounted)
- Zero the [GSENSOR](#) readings
- Connect analogue (SD) cameras
- Setup camera rate/quality as required e.g. [NORMAL RECORD](#)
- Setup the [ALARM INPUTS](#) for ignition, indicator L/R, brake, reverse, other...
- Set the [POWER OPTION](#) to WAKE WHEN IGNITION “YES”
- Set the POWER OPTION to WHEN IGNITION OFF “KEEP ON FOR 30 MINS”
- Set POWER STATE to RECORD
- Set ENABLE RECORD BUTTON to NO

OPTIONAL

- Connect, power and configure [IP Camera](#).
- Setup additional [ALARM INPUTS](#) .
- Setup the [SD RECORDING](#) parameters if SD is being used (format SD card)
- Enable [AUDIO](#) and set the sensitivity (if mics being used)
- Setup the [VIDEO OUTPUT](#) for MAIN and AUX to display camera output
- Add vehicle ID / Registration number to the [Camera text](#)
- Enable [GPS](#) (and set correct BAUD rate)
- Enable [IBUS](#) (Transport for London diagnostic reporting)
- Connect WiFi module for [LANLink](#)
- Connect [Bridge Alert](#)
- Connect [CANLink](#)

6.6.3 Mechanical Data / Fixing Specification

(measurements shown in mm);

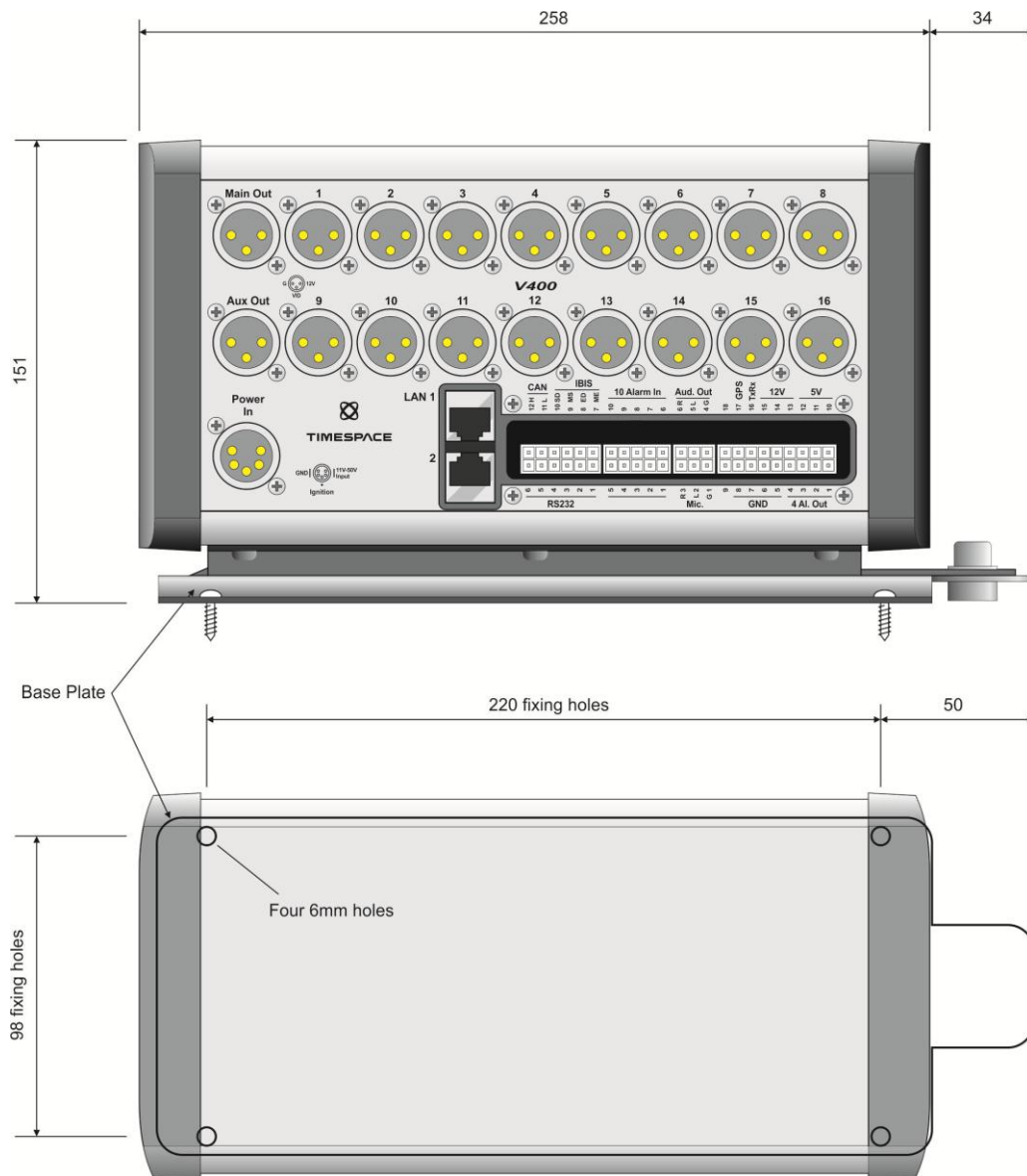

Figure 12 V400 Measurement Data

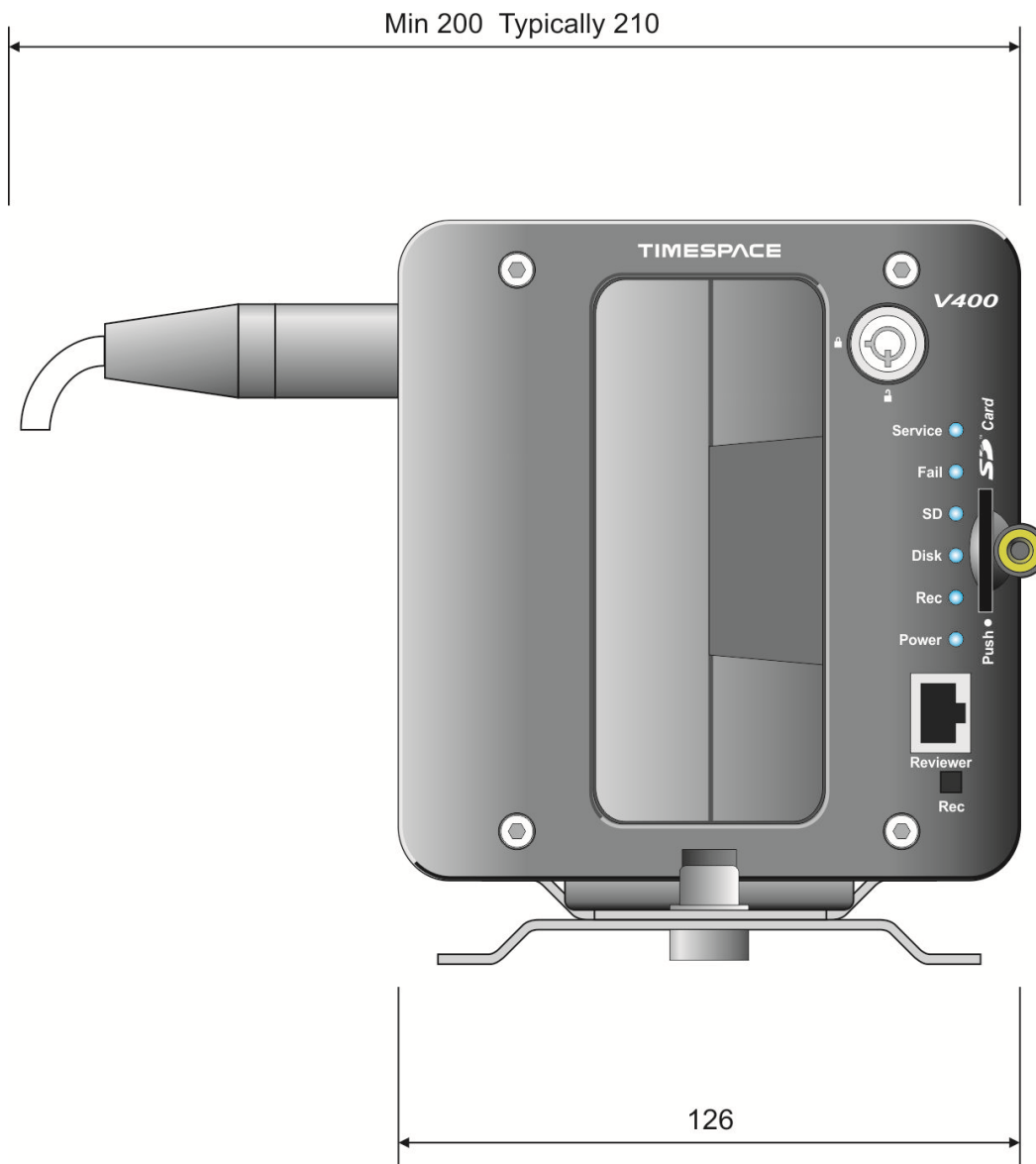

Figure 13 V400 Front Panel Measurement Data

6.6.4 Mounting Plates

The V400 has a wide metal peg at the rear which slots in to the base plate. The front of the V400 can then be screwed down to the base plate using an **M8 bolt** (provided). A 6mm Allen key will be required.

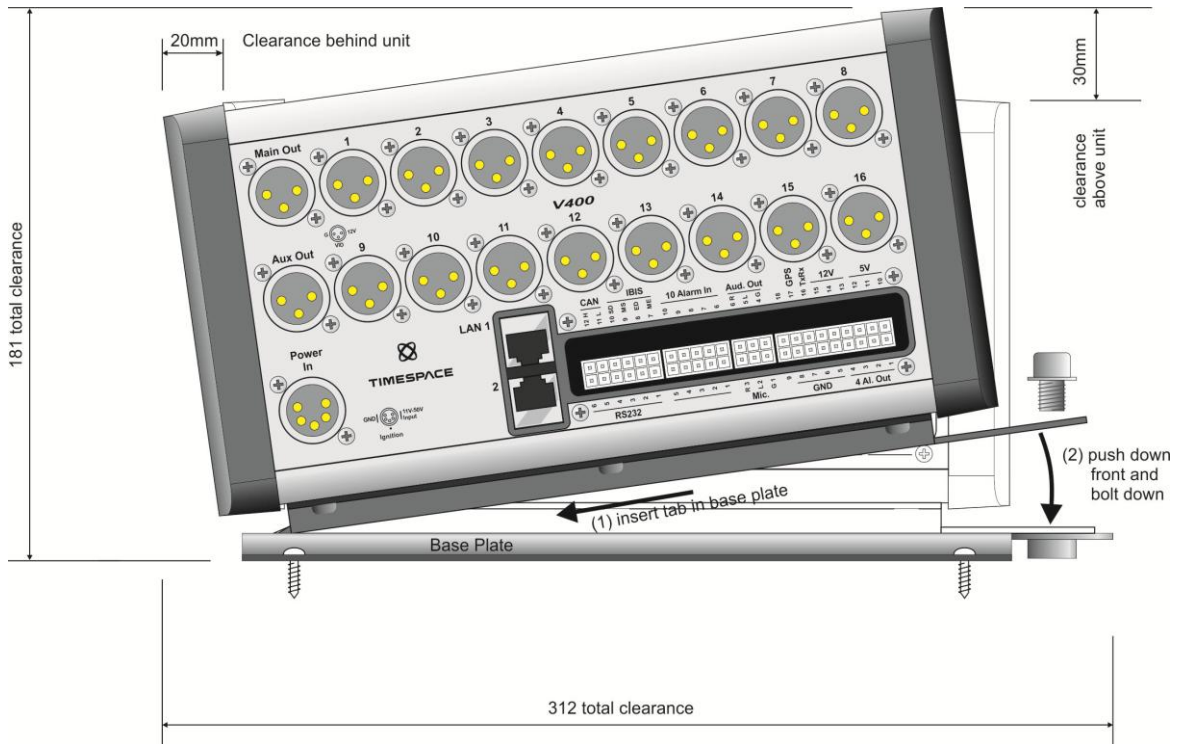
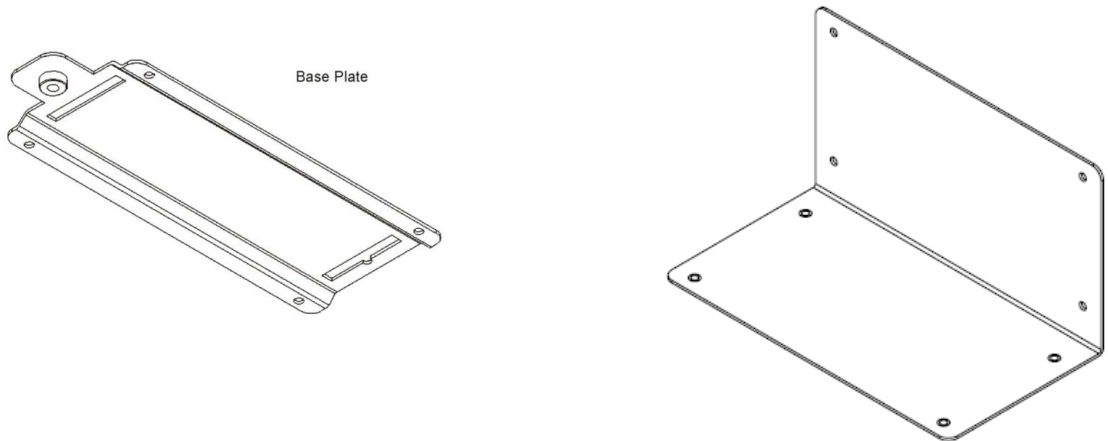

Figure 14 Mounting Plates



6.6.5 Alarm I/O Wiring

Alarm inputs are pulled to ground via a resistor so will read 0V if left disconnected or floating.

See Alarm **input** circuit below:

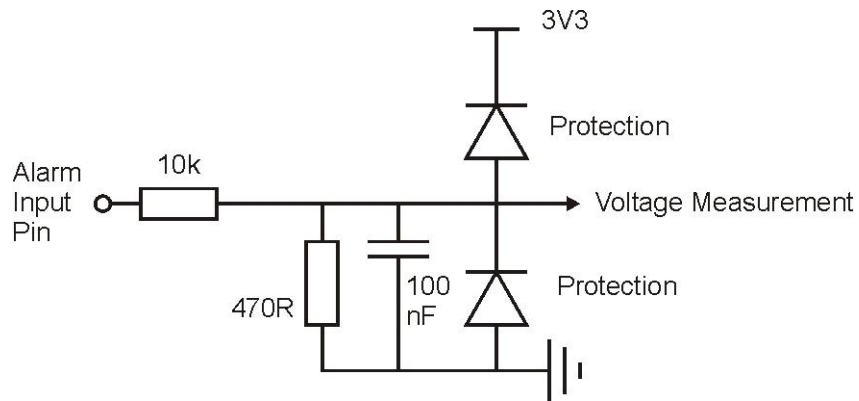

Alarm **output** circuit below:

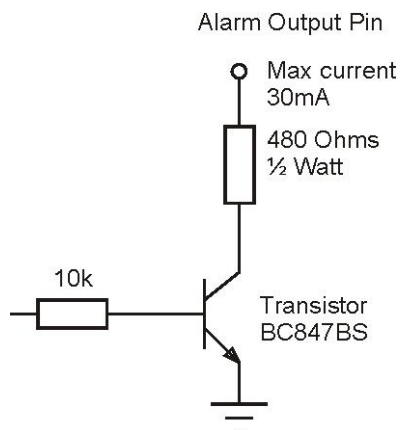

Figure 15 Alarm Input/Output Wiring

See [ALARM INPUTS](#) and [ALARM OUTPUTS](#) menus for specific trigger settings.

6.6.6 Connecting an IP camera

An IP camera is connected to the V400 DVR using a RJ45 cable CAT 5e or CAT 6 to the LAN2 ethernet port of the DVR – see Figure 11 Ethernet Connector.

Please note that the V400 is not POE and therefore the IP camera needs to be power externally either from the V400 DVR or another source.

NB: the output voltage on the 18-way Molex from the DVR will be 0.5V below the DVR's input voltage.

6.6.7 Wiring a line level microphone

The diagram below shows how to wire a line-level microphone into the V400. Two resistors are required per channel. This should remove with the need to reduce the level by mechanical means.

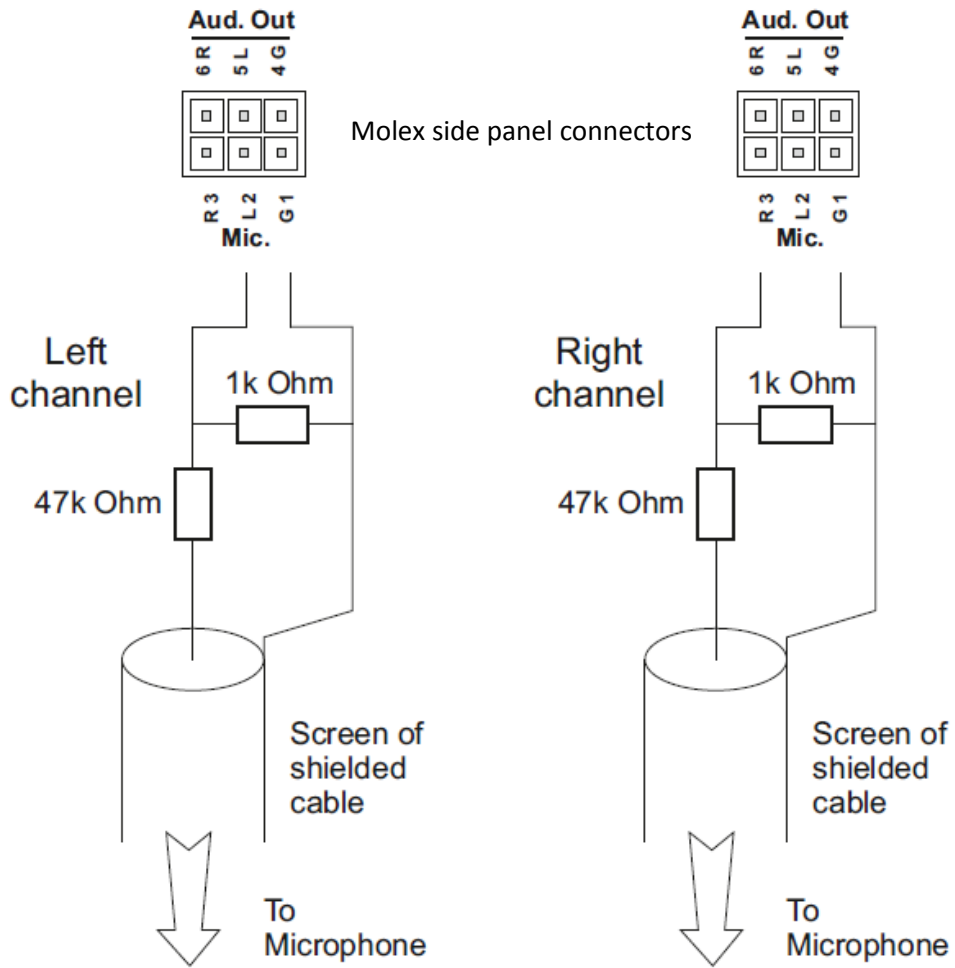

Figure 16 Wiring a line level microphone

6.6.8 Installation Spare Parts List

POWER CONNECTOR

Neutrik NC5FXX-B (solder bucket)

CAMERA INPUT / VIDEO OUTPUT

Neutrik NC3FXX-B (solder bucket)

Neutrik NC3FXX-HA (crimp)

Neutrik HA-3FXX (spare crimps, 50off per bag)

Crimp tool/Die (for the above) Neutrik HX-R-BNC / DIE-R-HA-1

	Molex PN	Farnell PN	RS PN
MOLEX CONNECTOR			
12 Way Molex Mini-Fit Jr Plug	39-01-2120	151-871	484-1805
10 Way Molex Mini-Fit Jr Plug	39-01-2100	151-870	484-1798
6 Way Molex Mini-Fit Jr Plug	39-01-2060	151-868	484-1760
18 Way Molex Mini-Fit Jr Plug	39-01-2180	996-3251	172-9027
Crimp Sockets for the above Molex (for wire size 18-24AWG)	39-00-0039	973-2195	172-9134
Crimp Tool (16-24AWG)	63819-0900	160-2636	501-083
Extraction Tool	11-03-0044	525-080	215-5900

MICROPHONES

Farnell – 335-9621

CPC – MP33125

Microphones must be wired with screened cable where the screen is connected to the GND and the centre core is connected to the microphone signal. Timespace have tested using 6m of Vandamme microphone cable (Vandamme part number 268001C, Farnell part number 798-289). Also possible is RG179 or RG59 video cable for short <6m runs.

7. Service And Maintenance

7.1 Maintenance Regime

There is no requirement for regular maintenance or returning the DVR to Timespace Technology. There are no user-changeable parts in the DVR. The battery in the V400 is designed for a life in excess of 15 years.

7.2 Service And Fail LED

The Service and Fail LED's on the V400 front panel give a positive indication that a system fault has occurred.

If the Service LED is lit then the system will most likely be functional but may not be performing as intended. An example may be one of the cameras has failed.

If the Fail LED is lit then the system will not be functioning and requires immediately attention. An example may be that the hard disk cartridge has failed.

The Service/Fail conditions are stored on the V400 for review. Each condition has an identifiable code and associated description. The service log can be viewed here; SETTINGS MENU > ADVANCED > VIEW SERVICE LOG menu.

The LED will remain lit and the problem which caused the Service LED to light will be listed in the log until the log is reset by selecting RESET SERVICE LOG.

A full list of [Service Codes](#) is in the table on the next page.

7.3 Service Codes

SERVICE CODE / NUMBER	DESCRIPTION
SERV_CAMOPEN	1** No current on power input to camera ** and no camera signal.
SERV_CAMSHORT	2** Over-current on power input to camera ** and no camera signal.
SERV_CAMSIGNAL	3** Camera disconnected for cameras 1-16 => codes 301-316.
SERV_CAMTYPE	4** Check camera 1-16 => codes 401-416.
SERV_CAMDISC	811 Camera disconnected for camera.
SERV_HDDSMART	812 S.M.A.R.T Info.
SERV_LOWFPS	813 FPS lower than threshold.
SERV_TIMEERROR	815 Time error.
SERV_RTC_ERROR	816 RTC battery fail.
SERV_CHECKSIM	817 Modem send error - check simcard.
SERV_DIAL_OUT_FAIL	818 Modem error - dial out failed (image over gsm).
SERV_SMTP_FAIL	819 Failed to send email.
SERV_MAIN_VOUT	820 Incorrect voltage on Main video output.
SERV_AUX1_VOUT	821 Incorrect voltage on Aux1 video output.
SERV_AUX2_VOUT	822 Incorrect voltage on Aux2 video output.
SERV_AUX3_VOUT	823 Incorrect voltage on Aux3 video output.
SERV_EXT_LOG	835 External control log (ext command).
SERV_CAMDISC_REPEAT	840 Intermittent camera connection.
SERV_USR_RESET	863 Log reset by user.
SERV_HDD_DELETE_FILES	864 Operation to delete all recording files on HDD did not complete.
SERV_HDD_SECURE_WIPE	865 Secure disk wipe on HDD did not complete.
SERV_SD_DELETE_FILES	866 Operation to delete all recording files on SD did not complete.
SERV_SD_SECURE_WIPE	867 Secure disk wipe on SD did not complete.
SERV_BRIDGE_ALERT_NC	868 Bridge Alert controller is not connected.
SERV_UNSAFE_SHUTDOWN	870 Unit was not shutdown gracefully.
SERV_ACC_NO_CALIBRATION	898 Accelerometer not calibrated.
SERV_NOTRECORDING	899 special for IBUS - not recording
SERV_FAIL_HDD_PACKET_WRITE	900 HDD packet write fail.
SERV_FAIL_HDD_PACKET_READ	901 HDD packet read fail.
SERV_FAIL_HDD_SECTOR_WRITE	902 HDD sector write fail.
SERV_FAIL_HDD_SECTOR_READ	903 HDD sector read fail.
SERV_FAIL_SD_READ_WRITE	904 SD card read/write fail.
SERV_FAIL_SD_FAIL	905 SD card failure (replace and format SD card.)
SERV_FAIL_SD_ERROR	906 SD card error (replace SD card.)
SERV_FAIL_H264_CODEC_0	907 H264 Codec (0) Error (rebooting).
SERV_FAIL_H264_CODEC_1	908 H264 Codec (1) Error (rebooting).
SERV_FAIL_LOW_BATTERY	909 Low battery - recorder stopped.
SERV_FAIL_HDD_DIR_FULL	910 HDD full, failure to create file on Hard Disc.

SERV_FAIL_SD_DIR_FULL	911	SD card full, failure to create file SD Card.
SERV_FAIL_IPCAM_IPERR	912	IP Camera address incorrectly configured, doesn't match VLAN2 subnet.
SERV_FAIL_QUOTA_TEST	998	In-house fail quota testing.

8. Software

8.1 V400 Software and Updates

Timespace recorders use proprietary embedded software in the form of **.XOS** files. Software updates for Timespace DVRs and [PCLink Suite](#) are available through authorised distributors or by contacting Timespace support; support@tspace.co.uk. From PCLink V7.2 onwards, updates can be automatically [downloaded within PCLink](#).

There are a number of ways to upload a new version of software onto Timespace DVRs:

1. Software can be uploaded to DVRs via Timespace's [LANLink](#) fleet management platform – “XOS jobs” can be created on LANLink to upload software to individual or multiple DVRs.
2. Software can be uploaded manually onto a DVR via the removable cartridge or SD card – both requiring a Timespace [Reviewer](#) to access the DVR's menu system.
3. For V400 software later than V1.6.0, software can be uploaded onto a DVR via an SD card without requiring a Timespace Reviewer to access the DVR's menu system.

NB: V400 software Version 1.6.0 is required to be in use on the DVR before subsequent releases of software can be installed via this automatic SD card method.

8.1.1 Software upload via LANLink

Timespace's LANLink fleet management platform is a vehicle CCTV health status and footage download system. Installed on a server, the LANLink engine communicates with vehicle DVRs via depot WiFi or 3/4G. When the vehicle is in WiFi or 3/4G range, LANLink periodically downloads CCTV health status, file system; camera snapshot, GPS and vehicle CAN engineering information from the DVR, displaying it in a series of web pages.

LANLink can create “jobs” to upload new software to individual or multiple DVRs, automating the process and avoiding the need for staff to visit the vehicle to manually upload new software.

Contact Timespace for further details of LANLink, including an outline specification for a LANLink server.

8.1.2 Manual Software Upload

Software can be uploaded to the DVR by copying an XOS file onto the removable cartridge or SD card using the PC/[USB interface](#), then inserting the cartridge/SD card into the recorder and navigating to the relevant menu (see below) using the Timespace [Reviewer](#). An example of the .XOS file name is **V400 V1.1.0.xos**

1. Using the [USB interface kit](#), copy the .XOS file from the PC to the cartridge/SD card, ensuring that no other XOS files already exist on the disk.
2. Insert the cartridge into the V400 and turn the key lock to the locked position.
3. Once the V400 has initialised, use the [Reviewer](#) to navigate to the DVR's SETTINGS MENU > ADVANCED > and select [LOAD SOFTWARE/SETTINGS](#).
4. Select LOAD FROM: > HD or SD as required
5. Select from three Load options:
 - LOAD WITH FACTORY SETTINGS (all menu settings will be reset to default values).
 - LOAD WITH CURRENT SETTINGS (menu settings will be maintained where possible).
 - LOAD WITH XOS SETTINGS (menu settings will be loaded from the cartridge/SD card).

In all LOAD instances, the XOS will be loaded from the cartridge/SD card into the V400 internal flash memory. The "with XOS settings" option will also load the *Settings* from the cartridge/SD card e.g. if replicating settings from another V400. The load will take approximately 30 seconds and when the V400 reboots, the current software version is displayed on screen. It can also be checked in the SETTINGS MENU > SYSTEM SETTINGS > SYSTEM INFO menu.

WARNING – V400 MAY BECOME UNUSABLE IF POWER TO THE UNIT IS LOST DURING A SOFTWARE UPGRADE.

8.1.3 Software Download

Software can be downloaded from the DVR to the cartridge/SD card. This feature can be used to replicate settings from one DVR to another when setting up multiple units.

1. With the cartridge locked in place in the V400, go to the SETTINGS MENU > ADVANCED and select the [SAVE SOFTWARE/SETTINGS](#) option.
2. Select SAVE TO: > SD or HD as required
3. Select from three SAVE options:
 - SAVE SYSTEM SOFTWARE
 - SAVE MENU SETTINGS
 - SAVE CONFIG DATA – saves the [TSCONFIG](#) file for IP Camera settings.

This will save the current V400 Software/Menu Settings/Config data to the file on the cartridge/SD card. The cartridge/SD card could then be used in another V400 to load the Software and Settings (using the above LOAD WITH XOS SETTINGS option). Also, the current.xos file could be copied from the cartridge onto a PC using the [USB kit](#) and kept as a master settings file.

8.1.3.1 Software download via PCLINK

PCLink Suite V7.2 onwards includes a software download feature for acquiring the current and future software release for PCLink Suite and Timespace Digital Video recorders.

From the **Help** menu within PCLink, select **Updates** and choose from the following;



Check for Latest Unit Updates... PCLink will connect to the internet and check for updates for PCLink and DVR operating software. If this is the being run for the first time, updates will be found and downloaded. If on subsequent checks no new versions are available, the download will be skipped. Some basic user information will be collected and the option to be included in future software and product notifications.

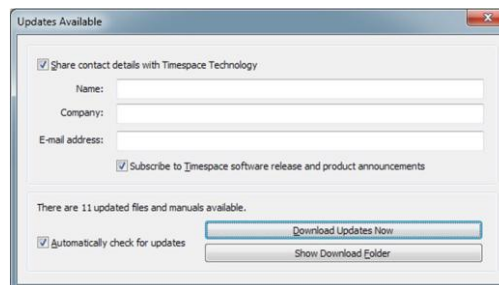

Show Downloaded Updates... PCLink will open the local folder that the updates were downloaded to.

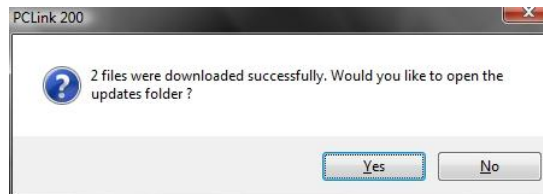

If updates are available for Timespace DVRs, the downloaded **.xos** files will be stored in the DVR sub folder e.g. *Update\V400\V400 V1.6.0.xos*

If a PCLink Suite update is available it will be downloaded as a **.zip** file using the PC's Internet browser, giving the user the opportunity to **save** the file to their preferred folder. Once complete, the file must be unzipped to a temporary folder and **TSSplash.exe** run (double clicked). This will initiate the PCLink installer.

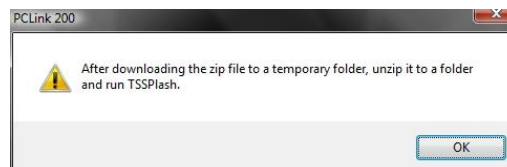

8.2 PCLink Suite



Timespace's proprietary PCLink Suite consists of applications that allow Playback, Live View, Configuration and Download of recorded files from the X, K and V series range of digital video recorders.

NB: Connection of an IP Camera to enable Live Remote Live View will reduce the available IPS for other recording methods. For further details see [RESOURCE ALLOCATION](#).

Detailed instructions of each application within PCLink Suite can be found in the PCLink Suite manual, available on our website www.tspace.co.uk

Application overview;

- PCLink
- Review recorded footage via USB cable connected to removable cartridge.
 - Review recorded footage over IP connection to the X300/V400.
 - Live view of cameras (multi channel support).
 - Remote configuration of X300/V400 menu settings.
 - Download file remotely (separate FTP client can also be used to download files).
- RemoteLink
- Review recorded footage over GSM / IP connection to the X200.
 - Live view of cameras (single channel support).
 - Remote configuration of X200 menu settings.
- LANLink
- Automatic Health checking over IP connection.
 - Automatic and scheduled downloading of footage.
- XCommunicate
- Download X200 files remotely (single file download support).
- ImageLink
- X300/V400 can send a snapshot image to a PC using a connected GSM modem.
- SafetyLink
- Review G-Sensor events that have exceeded the configured threshold.

8.3 LANLink

The screenshot displays the Timespace LANLink web interface. At the top, there is a navigation bar with tabs for 'Current Status', 'Units', 'Jobs', 'Health History', and 'CAN Health'. The main content area is titled 'Unit Status View (6512-SC)' and shows a table of vehicle units. The table has columns for ID, Name, Fleet, Hardware, and a grid of status icons for dates from 23 Jan to 14 Jan. Below the table, there are sections for 'Health Text' (showing GPS position and unit status), 'Snapshots' (a row of camera thumbnails), and 'GPS Mapping'.

Timespace's proprietary LANLink fleet management platform is a vehicle CCTV health status and footage download system. Installed on a server, the LANLink engine communicates with vehicle DVRs via depot WiFi or 3/4G. When the vehicle is in WiFi or 3/4G range, LANLink periodically downloads CCTV health status, file system; camera snapshot, GPS and vehicle CAN engineering information from the DVR, displaying it in a series of web pages.

Contact Timespace for further details of LANLink, including an outline specification for a LANLink server.



9. Appendices

9.1 Appendix 1 – Manual revision history

Changes in TT0904 Issue 5, 11th October 2022

Section	Details
Front cover	Date, issue number and software version updated.
Throughout	IP camera now identified as IP1 rather than camera 17
3	Main Menu screenshots updated to include IP Camera View
3.1.2	Timer Recording screenshot and text corrected with new wording After Timer
3.1.3.3	Alarm Input functions updated to include using JPEG Image on Aux
3.1.5	Added IP Camera view screenshot and text
3.1.7.2	Added Audio Test Duration to text and updated screenshot
3.1.9	Main video output. Amended text relating to RTSP
3.1.11	Aux video switcher Added instructions on displaying a JPEG on the Aux switcher.
3.2.5	Added File retention feature to screenshot and text
3.3.7	Bridge Alert - amended text to clarify GPS accuracy and warning distance
App 9.1	Updated list of changes
App9.3	Cartridge Range doc – Issue 6

9.2 Appendix 2 – V400 Data Sheet







Stand alone recorder



Live view using Reviewer or video out to monitor



Review recordings directly from a removable cartridge



Multi-channel live view and wireless download of recordings



Bridge Alert System



CANLink data recording

Performance	V400-08	V400-12	V400-16
Standard	PAL/NTSC	PAL/NTSC	PAL/NTSC
Video recording global image rate	100 FPS	150 FPS	200 FPS
Analogue video inputs	6	12	16
Image rates Min - Max selectable by camera	1 - 25 FPS	1 - 25 FPS	1 - 25 FPS
Image Resolution (pixel)	2CIF - 720 x 288	2CIF - 720 x 388	2CIF - 720 x 388
Image bit rate - quality setting	6 (TL setting VHigh)	6 (TL setting VHigh)	6 (TL setting VHigh)
IP Camera Resolution	1080P	1080P	1080P
Image rate Min - Max	1 - 25 FPS	1 - 25 FPS	1 - 25 FPS
Image bit rate	8 MB/Sec	8 MB/Sec	8 MB/Sec
Audio microphone input	2	2	2
Audio line out	2	2	2
Video out Main / Aux - Configurable	2	2	2
Video Streaming Live view - multi channel	25 FPS	25 FPS	25 FPS
SD Card recording rate - multi channel	25 FPS	25 FPS	25 FPS
Hard disk capacity options	500GB, 1TB or 2TB	500GB, 1TB or 2TB	500GB, 1TB or 2TB
Solid State Disk	500GB, 1TB	500GB, 1TB	500GB, 1TB
SD card capability	4-32GB	4-32GB	4-32GB
G Sensor	3 axis	3 axis	3 axis
Alarm input	10 selectable	10 selectable	10 selectable
Alarm output	2V - 24V Level 4 (Logic output)	2V - 24V Level 4 (Logic output)	2V - 24V Level 4 (Logic output)

Optional Features	V400-08	V400-12	V400-16
25 FPS global SD memory card back up (analogue only) - SDHC 4GB up to 32GB			
File download via SD card			
Bridge Alert			
WiFi / mobile router			
CANLink data recording (view in sequence with recorded footage)			
RTSP streaming (enabled via LANLink)			
MediaLink			

Connections / Interfacing	V400-08	V400-12	V400-16
Analogue Camera	3 pin XLR	3 pin XLR	3 pin XLR
IP Camera	RJ45	RJ45	RJ45
Video out (Main and Aux)	3 pin XLR	3 pin XLR	3 pin XLR
Audio microphone In	6 way Molex Mini	6 way Molex Mini	6 way Molex Mini
Audio line out	Fit Jr Plug	Fit Jr Plug	Fit Jr Plug
Timespace Reviewer	RJ45	RJ45	RJ45
LAN 1 W/LAN / 2S	RJ45	RJ45	RJ45
LAN 2 TTL BUS	RJ45	RJ45	RJ45
GSM / GPS / RS232	18 way Molex Mini	18 way Molex Mini	18 way Molex Mini
Alarm Inputs	Fit Jr Plug	Fit Jr Plug	Fit Jr Plug
Alarm / LED output - Configurable	10 way Molex Mini	10 way Molex Mini	10 way Molex Mini
Power input	5 pin XLR	5 pin XLR	5 pin XLR
Power output	12V and 5V 18 way Molex Mini Fit Jr Plug	12V and 5V 18 way Molex Mini Fit Jr Plug	12V and 5V 18 way Molex Mini Fit Jr Plug

Physical Characteristics	V400-08	V400-12	V400-16
Enclosure	Extruded aluminium, with moulded end caps		
Dimensions (mm)	292(x) 132(w) x 143(h) including mounting plate		
IP rating	IP50		
Operating temperature range	-10 to 50 °C		
Humidity	10 - 90% r.h., non condensing		
Mounting options with quick release bracket	Screw-mounted any axis orientation		
Power supply input	11 - 50V DC polarity protected		
Continuous power - without Reviewer	12W		
Continuous power - camera on (typical)	33W		
Continuous power - without Reviewer and in sleep mode	0.5W		
Maximum current - start-up	1.5A with camera and Reviewer		
Continuous power (maximum)	80W Ancillary equipment dependant		
Power up time to recording	20 seconds		
External power output	5V DC 2A / 12V 2A		
Video out - Main / Aux power output	12V 2A per monitor		
Maximum external monitor surge	6A at 12V for 20ms		
Weight - including removable cartridge and mounting bracket	2.61kg		

General Features
Auto record on power-up or single button start / stop recording
Recorder status indicators (6 LEDs)
Simultaneous record, live view and file download
H.264 (MPEG-4 Part 10) compression
Removable suspended hard disc media cartridge - lockable
Simple, intuitive menu system with help screens
Optional embedded GPS for position & speed
Normal and alarm triggered recording
Local set-up and configuration using Timespace Reviewer
Remote control via RS322 interface
Power-saving shutdown with wake-up on alarm, timer or motion
Low temperature sensor and heater
Short circuit protection - video inputs
Multi ranging PSU with power monitoring diagnostics
Integration with Timespace LANLink fleet management software
Gsensor-triggered alarms for automatic downloads

PCLink / LANLink
Remote set-up and download via LAN, WiFi or mobile networks
PC Multi Cam LiveView, playback, via optional WiFi or mobile router
Image search by time / data or filename - PCLink
Quick review alarm event footage markers
Face-blurring tool
View vehicle CAN data in sequence with video footage
Camera and DVR health check via simple traffic-light colour indicators

Security Features
Proprietary single file video format XBA
Each Image watermarked (SHA-2 AES Authentication - 256 bit)
Embedded camera number, date and time in each image

Timespace Technology Ltd reserves the right to amend product specifications without notice and without incurring obligation.

TIMESPACE

Timespace Technology Ltd Lakeview Court Errinne Business Park Huntingdon PE29 6UA UK

t: +44 (0)1480 414147 f: +44 (0)1480 414146 e: mail@tspage.co.uk www.tspace.co.uk

TT0707 Issue 5

156

9.3 Appendix 3 – Cartridge Range

Timespace Cartridge Range				
Description	X100 DVR	X200 DVR	X300/X500/R500 DVRs	V400/V500/V600 DVRs
	Part No.	Part No.	Part No.	Part No.
500GB Hard Disk Cartridge	-	T401-500	T601-500	T701-500
1TB Hard Disk Cartridge	-	-	T601-1000	T701-1000
2TB Hard Disk Cartridge	-	-	T601-2000	T701-2000
4TB Hard Disk Cartridge	-	-	T601-4000	T701-4000
120GB Solid State Cartridge	T403-120	T403-120	T603-120	-
240GB Solid State Cartridge	-	-	T603-240	-
500GB Solid State Cartridge	-	-	T603-500	T703-500
1TB Solid State Cartridge	-	-	T603-1000	T703-1000
2TB Solid State Cartridge	-	-	T603-2000	T703-2000

Please note:

- All cartridges are covered by 30 month warranty

TT0713 Issue 6, 18th March 2021.

9.4 Appendix 4 – Hard Disk Best Practice Guide

Best Practice Guide



Hard Disk Cartridges

This Best Practice Guide has been produced by Timespace Technology to advise users of Timespace digital video recorders (DVRs). It details Timespace's recommended best practice for use and management of the DVRs' Hard Disk Cartridges – "disks". For further advice contact: support@tspace.co.uk.

All Timespace DVRs and disks

1. *DVR software* – Timespace recommends that DVRs should always use the latest release of DVR software. Details of current software versions can be found at www.tspace.co.uk. DVR software updates are available from your installer, from Timespace at support@tspace.co.uk and via Timespace's proprietary PCLink and LANLink software.
2. *Deleting recordings* - never delete recordings or format the disk on a PC – always perform this operation on the DVR unit.
3. *USB connectors* – if using a Timespace Cartridge Station with a disk, plug in both leads of the cartridge station. For best performance, plug into the rear USB port of a PC.
4. *Files not visible?* - if files can be seen on the DVR unit but not on a PC, perform "Check And Correct" on the DVR (found in Settings Menu > System Settings > File System > File System Check Menu). This should correct the error, and footage will then be viewable on a PC.
5. *Time and date issues* – Check that the time and date set on the DVR unit is correct (found in Settings Menu > System Settings > Time and Date). If time and date is showing 00:00:00 or is significantly out, then the DVR will need attention – contact your installer for service information.
6. *Disk refurbishment* - to ensure system reliability, it may be prudent to consider refurbishment of older disks. It may also be possible to upgrade disks to larger capacities – contact your installer for details.

X100 and X200 DVRs and disks only

7. *Swapping disks* - if a disk is swapped between an X100 and an X200 unit, delete all recordings prior to use. This prevents confusion with footage and different X100/X200file types.

X100 DVRs and disks only

8. *X100 disk capacity* – the X100 only supports disks 240GB or smaller.

../END

9.5 Appendix 5 – 37 Way D-Type connector / 9 pin serial port

Very early versions of the V400 hardware had a 37 Way D-Type connector and 9 pin serial port in place of the Molex type connectors. Here are the details of the 37 way;

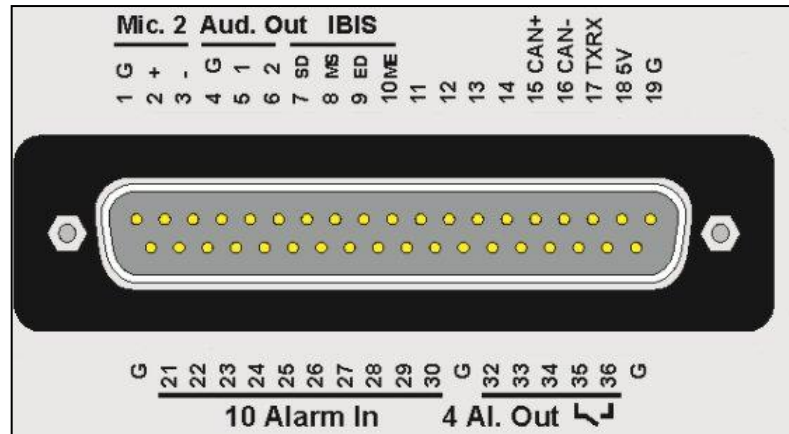

Figure 17 37 Way D-Type connector/9 pin serial port

Pin		Pin	
1	MIC RGND	20	GND
2	MIC RP	21	ALARM INPUT 1
3	MIC RN	22	ALARM INPUT 2
4	AUDIO OUT GND	23	ALARM INPUT 3
5	AUDIO OUTPUT 1	24	ALARM INPUT 4
6	AUDIO OUTPUT 2	25	ALARM INPUT 5
7	IBIS WBSD+	26	ALARM INPUT 6
8	IBIS WBMS-	27	ALARM INPUT 7
9	IBIS WBED+	28	ALARM INPUT 8
10	IBIS WBEM-	29	ALARM INPUT 9
11		30	ALARM INPUT 10
12		31	GND
13		32	ALARM OUTPUT 1
14		33	ALARM OUTPUT 2
15	CAN High OUTPUT	34	ALARM OUTPUT 3
16	CAN Low OUTPUT	35	ALARM OUT RELAY PIN1
17	CAN TXRX	36	ALARM OUT RELAY PIN2
18	OUTPUT +5V	37	GND
19	GND		

RS232 GPS CONNECTOR

9 way male D-type connector (DB9) which can be used to support 1 or 2 RS232 peripherals.



PIN	TYPE	I/O	TYPE
3	TD, Transmit Data	>	Serial Data
2	RD, Receive Data	<	Serial Data
7	RTS, Request to send	>	Handshaking
8	CTS, Clear to send	<	Handshaking
4	DTR, Data terminal ready	>	V400 outputs 5V
6	DSR, Data set ready	<	Ignored by V400
1	DCD, Data carrier detect status	<	Detect modem status
9	RI, Ring Indicator	<	Ignored by V400
5	GND, Ground		

> V400 output

< V400 input

Using a conventional cable (DB9 male to DB9 female straight through (1-1, 2-2, 3-3 etc.)) the V400 can be connected to a modem. Alternatively, two RS232 peripherals such as GSM modem and GPS device can be connected simultaneously. Here is an example of the wiring;

PIN	TYPE	I/O	TYPE
Device 1 (Modem)			
3	TD, Transmit Data	>	Serial Data
2	RD, Receive Data	<	Serial Data
7	RTS, Request to send	>	Handshaking
8	CTS, Clear to send	<	Handshaking
1	DCD, Data carrier detect status	<	Detect modem status
5	GND, Ground		
Device 2 (GPS)			
4	5V, Supply (500mA max)	>	Power
9	RD, Receive Data	<	Serial Data
5	GND, Ground		

> V400 output

< V400 input

NB: In order to meet the EMC standards with which the V400 is compliant it is important that shielded cables are exclusively used. All of the signal grounds should be common inside the D-

Type connector and connected to a metal back-shell in order that the cable run and D-Type connector are shielded.

Parts list;

37 WAY D TYPE (legacy part)

Farnell 154878 Multicomp

9 WAY RS232 (legacy part)

Farnell 1099052 Multicomp

AUDIO CONNECTOR

Neutrik NC3MXX-BAG

9.6 Appendix 6 – Certificates of conformity and type approval

9.6.1 EC Declaration of Conformity

EC Declaration of Conformity (CE)	
We	Timespace Technology Ltd Lakeview Court Ermine Business Park Huntingdon PE29 6UA United Kingdom
 declare that the	
V400 Digital Video Recorder	
 Meets the intent of the Directive 2014/30/EU European Parliament referred to as the Electromagnetic Compatibility (EMC) Directive. The product conforms to the following standards which have been listed in the Official Journal of the European Union.	
 EMC	
 Emissions - EN55032:2012	
Information technology equipment – Radio disturbance characteristics – Limits and methods of measurement.	
 Conducted - EN55024:2010	
Information technology equipment – Immunity characteristics – Limits and methods of measurement.	
	
Dr ROBERT HEYLEN TECHNICAL DIRECTOR 11 th September 2017	

9.6.2 E11 R10 Approval (Electromagnetic compatibility)



THE UNITED KINGDOM VEHICLE APPROVAL AUTHORITY

COMMUNICATION CONCERNING THE ~~APPROVAL GRANTED~~⁽¹⁾; APPROVAL EXTENDED⁽¹⁾;
~~APPROVAL REFUSED~~⁽¹⁾; ~~APPROVAL WITHDRAWN~~⁽¹⁾; ~~PRODUCTION DEFINITELY~~
~~DISCONTINUED~~⁽¹⁾ OF A TYPE OF ELECTRICAL/ ELECTRONIC SUB-ASSEMBLY⁽¹⁾ WITH
 REGARD TO REGULATION NO. 10.05



Approval No: 10R-056098

Extension No: 03

1. Make (trade name of manufacturer): Timespace Technology Ltd
2. Type and general commercial description(s): V400 Digital Video Recorder and Bridge Alert
 T716 (V400 with 16x Cameras)
 T716S (V400 with 16x Cameras)
 T712 (V400 with 12x Cameras)
 T708 (V400 with 8x Cameras)
 T709 Bridge Alert Module
3. Means of identification of type, if marked on the ~~vehicle/component~~ ⁽¹⁾ ~~separate technical unit~~ ⁽¹⁾
 Self-adhesive Serial No label that contains the part number
 - 3.1. Location of that marking: Label located top left of the digital video recorder
4. Category of vehicle: Not applicable
5. Name and address of manufacturer:
 Timespace Technology Ltd
 Lakeview Court
 Emine Business Park
 Huntingdon
 PE29 6UA
 United Kingdom
6. In the case of components and separate technical units, location and method of affixing of the approval mark: Self-adhesive label located top right of the V400 digital video recorder

EAT387318

An executive agency of the Department for Transport
 March 2017 Revision 4
 Page 1 of 3



E11 10R-09006 Extension 03

7. Address(es) of assembly plant(s):
Timespace Technology Ltd
Lakeview Court
Ermine Business Park
Huntingdon
PE29 6UA
United Kingdom
 8. Additional information (where applicable): See appendix
 9. Technical Service responsible for carrying out the tests: HORIBA MIRA Ltd
 10. Date of test report: As before and 30 October 2017
 11. No. of test report: As before and 1215608#01
 12. Any remarks: Approval to Supplement 1
 13. Place: BRISTOL
 14. Date: 08 JANUARY 2018
 15. Signature:  D LAWLOR
Chief Technical and Statutory Operations Officer
 16. The Index to the Information package lodged with the Approval Authority, which may be obtained on request, is attached.
 17. Reasons for extension: To cover
1) PSU removed and fitted onto the IF board.- re spin of the V400 IF PCB
2) Editorial corrections
- (1) ~~Strike out what does not apply.~~

EAT387318

An executive agency of the Department for Transport
March 2017 Revision 4
Page 2 of 3



9.6.3 E11 R118 Approval (Fire safety/burning behaviour of materials)



THE UNITED KINGDOM VEHICLE APPROVAL AUTHORITY

COMMUNICATION CONCERNING THE APPROVAL GRANTED⁽¹⁾ / ~~APPROVAL EXTENDED⁽¹⁾ /~~
~~APPROVAL REFUSED⁽¹⁾ /~~ ~~APPROVAL WITHDRAWN⁽¹⁾ /~~ ~~PRODUCTION DEFINITELY~~
~~DISCONTINUED⁽¹⁾~~ OF A COMPONENT TYPE PURSUANT TO REGULATION NO 118.03



Approval No: E11*118R03/00*1281*00

Reason for extension: Not applicable

SECTION I

GENERAL

- 1.1. Make (trade name of manufacturer): Timespace Technology Limited
- 1.2. Type: TDVRS
- 1.3. Means of identification of type, if marked on the device ^(b): Not applicable
 - 1.3.1. Location of that marking: Not applicable
- 1.4. Name and address of manufacturer:

Timespace Technology Limited
 Lakeview Court
 Ermine Business Park
 Huntingdon
 PE29 6UA
 United Kingdom
- 1.5. Location of the approval mark: Manufacturers label affix to component or packaging

ESV479167

An executive agency of the Department for Transport
 March 2018 Revision 0
 Page 1 of 1



E11*118R03/00*1281*00

1.6. Address(es) of assembly plant(s):

Timespace Technology Limited
 Lakeview Court
 Ermine Business Park
 Huntington
 PE29 6UA
 United Kingdom

SECTION II

1. Additional information (where applicable): See Appendix
2. Technical Service responsible for carrying out the tests: Vehicle Certification Agency
3. Date of test report: 04 February 2020
4. Number of test report: ESV479167
5. Remarks (if any): None
6. Place: BRISTOL
7. Date: 19 MARCH 2020
8. Signature:  D. LAWLOR
 Chief Technical and Statutory Operations Officer
9. The index to the information package lodged with the Type Approval Authority, which may be obtained on request, is attached.
 - (1) Strike out what does not apply (there are cases where nothing needs to be deleted, when more than one entry is applicable)
 - (b) If the means of identification of type contains characters not relevant to describe the vehicle, component or separate technical unit types covered in this information document, such characters shall be represented in the documentation by the symbol "?" (e.g. ABC??123??)

ESV479167

An executive agency of the Department for Transport
 March 2018 Revision 0
 Page 2 of 2



E11*118R03/00*1281*00

APPENDIX

to type-approval communication form No. E11*118R03/00*1281*00
concerning the type-approval of a component type pursuant to Regulation No. 118.03

1. Additional information. See Appendix
 - 1.1. Interior materials
 - 1.1.1. The direction which the component may be installed: ~~horizontal / vertical / both horizontal and vertical direction(s).~~⁽¹⁾
 - 1.1.2. Fulfils the requirements in paragraph 6.2.2.: ~~Yes/Not applicable~~⁽¹⁾
 - 1.1.3. Compliance has been checked for components approved as complete devices: ~~Yes/No~~⁽¹⁾
 - 1.1.4. Any restrictions of use and installation requirements: This device / material is prohibited from use within the engine compartment and any heating compartments
 - 1.2. Insulation materials
 - 1.2.1. The direction which the component may be installed: horizontal / vertical / both horizontal and vertical direction(s).⁽¹⁾ Not applicable
 - 1.2.2. Compliance has been checked for components approved as complete devices: yes/no⁽¹⁾
Not applicable
 - 1.2.3. Any restrictions of use and installation requirements: Not applicable
 - 1.3. Electric cables
 - 1.3.1. Any restrictions of use and installation requirements: Not applicable
2. Remarks: None

ESV479167

An executive agency of the Department for Transport
March 2018 Revision 0
Page 3 of 3



9.7 Appendix 7 - Splash Screen

SPLASH SCREEN – Enables use of a .BMP file to be displayed, for example an Operator/Company logo. Can be set to 5, 10, 20, 30, 60 seconds, or Until Exit (which requires user interaction to clear).

A tool can be provided on request to create the Splash Screen image in the correct format, from an input source. The input source should not be more than 1.5mb and should be a simple image with plain colours, approx 720x576. An example images is show below;

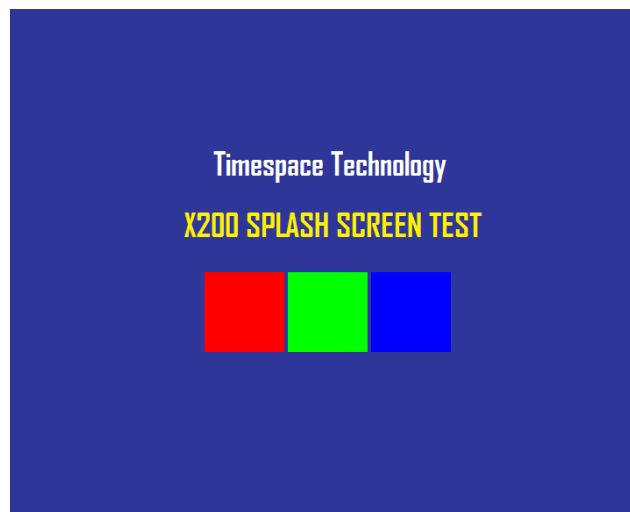

Once in the correct format (using the Timespace conversion tool), the image is placed on the V400 cartridge, named; Splash.ext. Once configured in the menu, the Splash Screen will be read from the disk and displayed.

Please contact support@tspace.co.uk for the conversion tool.

9.8 Appendix 8 - Transport for London IBUS diagnostic interface

Timespace has developed a diagnostic interface in conjunction with Transport for London (TFL) to monitor the status, performance and health of Timespace X200, X300, V400 and V500 digital video recorders on London Buses.

Data strings are passed between the DVR and the IBUS system every 5 minutes. In addition to the scheduled data packets, the DVR can be queried by sending it a proprietary text string. Several different data sets can be retrieved according to the input string.

The IBUS feature is available in software **X200 V1.9.0** onwards, **X300 V1.1** onwards and **V400** and **V500 V1.0** onwards. The IBUS menu is accessed using the short code; **9001234** on the X200 and X300 and via the menu system on the V400 and V500. The short code can be entered from any menu using the number keys on the [Reviewer](#).

```

      IBUS

IBUS ENABLED:  »NO

REMOTE IP ADDR: 192.168. 10. 20
LOCAL IP ADDR:  192.168. 10. 30
PORT:           22000
CONFIGURE IBUS
SET DEFAULTS

IBUS DEBUG:      NO
IBUS MESSAGE QUERY: 01
SEND MESSAGE QUERY NOW
  
```

IBUS ENABLED – The IBUS interface can be enabled/disabled by setting YES/NO accordingly.

IP ADDRESS – Sets the IP address of the receiving device (default IBUS LOCAL IP as above).

NB: IP address settings cannot be changed while recording is in progress – a warning will be displayed. Stop recording and amend settings as required before recommencing recording.

IBUS DEBUG - For testing purposes a debug mode can be enabled. This will increase the rate of messages sent out from the DVR to every 5 seconds. It is not recommended to leave debug turned on during normal operation.

The IBUS information can also be accessed using the RS232 command #IBUS. This command is only supported on the X300 & V400 over the serial port, no Telnet support.

Example setup of the IBUS interface on a **V400** DVR includes;

- Set recording parameters as required.
- Enter IBUS menu and set ENABLED to YES
- Navigate to the LAN menu and set the IP ADDRESS to 192.168.10.30 and the GATEWAY to 192.168.10.20

It is advised to set the correct date and time when enabling the IBUS feature and ensure no Service/Fail conditions are currently being displayed. **NB:** currently the V400 connects to the IBUS system's network port 4. In the case of the V400, LAN socket 1 is currently used for the IBUS interface.

9.9 Appendix 9 - Tokens / Protocol

The V400 is always looking for tokens to perform actions but no responses are monitored. The remote device should monitor the OK<R> messages that are returned. It is looking for all tokens apart from when writing file data. In this case only the "#ENDFILE<R>" is searched for.

All commands sent to the V400 are acknowledged, for example if the client sends #RECSTART<R>, OK<R> will be returned to the client to signify that the command was successfully carried out. In the case of commands like GETTIME and GETDATE, OK<R> will not be returned, but the data requested, followed by a <R>. In the case of PREVIOUSFILE and NEXTFILE, OK<R> will be replaced with either LAST<R> or FIRST<R> if there are no more files to play next or previous, respectively. When sending commands, the sender to the V400 can wait for an OK before sending another command, or one of the other variants listed above.

There may be a need for a hold off time between certain commands (e.g. 10 mS), as the V400 may take a finite time to do certain tasks. To add delay you could simply put spaces between one command and the next and these are ignored. The V400 does have a FIFO queue of 2048 bytes so can buffer data. Certain commands can be followed immediately with other commands for example:

```
#CAMERA_<1-16><R>#PLAY<R>           -play a given camera
#SETTIME_<12:23:45><R>#SETDATE_<23/09/10><R>   -set time and date
```

Definitions

- A space
- <> - Parameter, don't include brackets
- <R> - return (char 13)
- FAIL - File system failed to create file, aborted
- FAIL - File name is illegal
- OK - Acknowledgement, Command carried out
- CLIENT - The external equipment that is connected to the V400 via RS232 or Telnet
- BAUD Rate - This shall be selectable from within a menu
- <TEXT> - Textual data

Writing files

Write File command: **#WRITEFILE,<FILENAME><R>**

Close File command: **#ENDFILE<R>**

A return <R> character at the end of the "#WRITEFILE" command will signify the beginning of the writing process. All data from this point onwards will be written into the

file specified. If the file system fails to create the file for any reason, FAIL<R> will be returned to the client.

A check is done on the file name length, if the user overruns (number of characters in total is greater than 60), FAIL<R> will be transmitted to the client, and the write command is aborted. The user should only use uppercase letters and numbers in the filename and the space character. The extension “.EXT” is automatically applied by the V400, for example

Command	Created file
#WRITEFILE,REPORT<R>	REPORT.EXT
#WRITEFILE,TICKET DATA 6 DEC 2010<R>	TICKET DATA 6 DEC 2010.EXT

If the file has been created effectively, OK<R> will be sent to the client. The client may now proceed to send the file data. When the token #ENDFILE<R> is received, the file is closed, and the client will be sent OK<R>. A new file may now be opened if required. In the example below, all the text in BOLD is written to the file “TICKETS.EXT”

```
#WRITEFILE,TICKETS<R>
DATE: 24/12/2011
TIME: 11:48:00
LOCATION: KINGS CROSS
#ENDFILE<R>
```

Reading files

Read File command: **#READFILE,<FILENAME><R>**

A return <R> character at the end of the #READFILE<R> command will signify the beginning of the reading process. Data will now be transmitted from the V400 to the client. The handshaking line CTS on port 1 may be used if required to pause the data flow. If the file system fails to open the file for any reason, FAIL<R> will be returned to the client. A check is done on the file name length, if the user overruns, FAIL<R> will be transmitted to the client, and the read command is aborted. If all is good, OK<R> is sent followed by the file data followed the token #ENDFILE<R>. The following example reads the file “TICKETS.EXT”.

Sent to V400	Received from V400
#READFILE,TICKETS<R>	DATE: 24/12/2011
	TIME: 11:48:00
	LOCATION: KINGS CROSS
	#ENDFILE<R>

Recording

If for any reason recording stops, even if instructed to, the V400 will return #RECSTOP<R>

#DISKREMOVED<R> will be sent under two conditions.

- 1) The disk is removed from the V400 at anytime post V400 initialization.
- 2) Live view always has been enabled and the V400 boots without a disk.

#DISKIN<R> will be sent under two conditions.

- 1) The disk is inserted into the V400 at anytime post V400 initialization.
- 2) Live view always has been enabled and the V400 boots with a disk.

Control Commands

#RECSTART<R>	- start recording
#RECSTOP<R>	- stop recording
#STOP<R>	- stop playback
#PLAY<R>	- start playback (standard)
#REPLAY<R>	- play backwards (standard)
#WIND<R>	- fast forwards (standard)
#REWIND<R>	- rewind (standard)
#XPLAY_<FACTOR><R>	- plays at the specified factor speed (-/+)
#CAMERA_<1-16><R>	- camera to control
#LIVEVIEW<R>	- switch to live view
#AUTOLIVEVIEW<R>	- switch to live view automatic mode
#JOGFORWARD<R>	- one frame backwards
#JOGBACKWARD<R>	- one frame forwards
#GOTONEWESET<R>	- go to the newest recording
#GOTOOLDEST<R>	- go to the oldest recording
#GOTO_<HH:MM- DD/MM/YY><R>	- go to time DD:MM:YY_HH:MM
#GOTO_<HH:MM:SS-DD/MM/YY><R>	- go to time DD:MM:YY_HH:MM:SS
#SETTIME_<HH:MM:SS><R>	- sets the time
#SETDATE_<DD/MM/YY><R>	- sets the date
#GETTIME<R>	- gets the time
#GETDATE<R>	- gets the date
#NEXTFILE<R>	- when playing, skips to the beginning of the next file
#PREVIOUSFILE<R>	- when playing, starts at the beginning of the currently playing file. When stopped and #PREVIOUSFILE is issued twice, followed by a play, the previous file will begin playing from the beginning.
#GETFILETIMEDATE	- gets the current playing position of the currently play file.
#GETSTATS	- returns statistics
#DELETEALLREC	- removes all recording files from disk
#ALARMOUT<1-4>_0/1	- Turns ALARMOUT LED Output ON (1) or OFF (0)
#ALARMOUT<1-4><R>	- Returns the status of ALARMOUT, 0 or 1
#ALARMIN<1-10><R>	- Returns the status of ALARMIN, 0 or 1
#ALARMIN<1-10>1_0/1	- sets the state of the Digital input 1 ON(1) or OFF(0)
#CAMTEXT_<1-16>_<TEXT><R>	- writes text to the console at record time, Char 255 moves to the beginning of a new line. Maximum 49 characters per camera.
#DISKSTATUS	- returns #DISKREMOVED or #DISKIN
#MODESTATUS	- Returns #RECORD, #PLAY or #IDLE
#SETCAMTEXT_<1-16>_<TEXT><R>	- sets the camera text. This is fixed to 12 characters per camera.
#SETFILETEXT_<TEXT><R>	- sets the filename text. Max 12 characters.
#LOGRESET<R>	- resets the service log
#LOGREAD<R>	- reads the service log and returns up to the 10 latest entries

#MULTIVON<R>	- Turns Multiview On
#MULTIVOFF<R>	- Turns Multiview Off
#LOG_<TEXT><R>	- Logs a text message to the V400's service log (does not light service LED). Sending RESET LOG as the text marks off the LANLink should read the messages up to. OK<R> is returned if the daily quota of 10 has not been reached, other wise 10/DAY<R> is returned

Commands in Detail

#GETFILETIMEDATE

Gets the current playing position of the currently playing file. Please use #MODESTATUS to tell if the time you are reading is live play or if in idle mode, as the time you receive will ways be the current/last position played.

#GETSTATS

Will return the following stats in the same format. #END<R> signifies end of file. The stats may possibly grow in the future, but will be append to this list. Scanning for #END after the data has been retrieved. Data may be scanned for by capturing just after the colon (:) and just before the end of line <R>

```
Capacity: 500.11GB
Used: 0.38 %
Write Protected: 0.00 %
First File: 16:09:00 - 21/12/10
Last File: 16:50:00 - 21/12/10
Days Recording: 0.03
Model Number: Hitachi HTS545050B9A
Serial Number: 100924PBN400B7F2LW7L
#END
```

#DELETEALLREC

The #DELETEALLREC command will stop the current recording and delete all recording files. When complete, OK<R> will be returned
#LED1, #LED2, #ALARMOUT

The following 3 commands control the 2 digital outputs and the Alarm output. These settings will be OK'd with the current hardware states of the V400.

#ALARMOUT1_0/1<R> – Sets the active state for the alarm output CLOSE/OPEN.

..

#ALARMOUT10_0/1<R>

#ALARMOUT<R> - Returns the status of the ALARMOUT port, 0 = off, 1 = on

#ALARMIN1 - #ALARMIN10

Each one of the alarm inputs can be virtually activated by using the following commands, which control each alarm input independently. These settings will be OK'd the current hardware states of the V400.

#ALARMIN1_0/1<R>

..

#ALARMIN10_0/1<R>

By using these commands, a camera may be assigned to each alarm input, thereby allowing recording on each channel to be selective and/or allow for a different set of recording rates between Normal and Alarm recording

The following commands will READ the status of the ALARMIN pots:

#ALARMIN1<R> - Returns the status of the ALARMIN1, 0 = off, 1 = on

..

#ALARMIN10<R> - Returns the status of the ALARMIN10, 0 = off, 1 = on

#CAMTEXT

#CAMTEXT_1_HELLO WORLD<R> - "Hello world" will be written at the top left hand corner

#CAMTEXT_3_<255><255><255>HELLO<R> - "Hello" will be written on the 4 line on camera 3

If text has been assigned to a camera, simply issuing blank text will clear all RS232 overlay text from that camera. A maximum of 49 characters may be sent to the screen including new line control codes. e.g. **#CAMTEXT_3_<R>** will clear the text (please note the space after 3)

#SETCAMTEXT_<1-16>_<TEXT><R>

Sets the camera text as via the Camera Options menu on the V400. 1-16 is the camera selection followed by the actual text. This is fixed to 12 characters per camera.

#SETFILETEXT_<TEXT><R>

Sets the filename text for the V400 file system to use. Max 12 characters.

#LOGRESET<R> Resets the service log

#LOGREAD<R> Reads the service log and returns up to the 10 latest entries

Examples

CAMERA_1<R>	switch to camera 1 (either in live/auto view or during playback)
XPLAY_0.5<R>	plays forward at half speed
XPLAY_-3.2<R>	plays in reverse at 3.2 times real time rate
XPLAY_10<R>	plays forwards at 10x speed
SETTIME_12:23:23<R>	sets the time in the format HH:MM:SS
SETDATE_23/09/05<R>	sets the date in the format DD:MM:YY
#GETTIME<R>	to which 12:23:23<R> is returned
#GETDATE<R>	to which 23/09/05<R> is returned
#LED1_1<R>	turn LED1 on
#CAMTEXT_1_Hello><R>	writes "Hello" to the console at record time in the top left corner.

A windows demonstration tool is available with source code upon request by emailing support@tspace.co.uk

9.10 Appendix 10 - Health SMS Message Format

If a parameter is not known or not to be included (i.e. set to NO on the menu), then the char ‘-’ is used in the message. Three examples are shown below;

1,076812,BUS AO52 WXA,-,-,L,CNCC,064253 280509,120510 240509,S,212756120509,S,17,MODEM SEND ERROR

1,076812,BUS AO52 WXA,HUNTINGDON12,-,L,CNCC,064518 280509,120510 240509,-,064353 280509,S,63,LOG RESET

1,076812,BUS AO52 WXA,HUNTINGDON12,-,L,CNCC,064518 280509,120510 240509,-,-,-,-

FIELD	DESCRIPTION	VALUE
<1.type>	Reason health SMS has been sent	“0” - SMS POWER-UP. “1” - SMS SEND DAILY. “2” - SMS SEND NOW. “3” - SMS SEND NOW via incoming SMS.
<2.serial_num>	Unit serial number.	“Serial num” - The V400 6-digit serial number.
<3.veh_id>	Optional camera 1 text.	“Camera1 text” - Camera1 text, up to 12 chars. “NO ID” - No camera 1 text specified.
<4.veh_id1>	Optional filename text.	“Filename text” - Filename text, up to 12 chars. “NO ID1” - No camera 1 text specified.
<5.gps_pos>	Current or last GPS position.	“ddmmm.mmmmX dddmm.mmmmX” - GPS position “NO GPS DATA” - No GPS data available.
<6.last_curr>	Indication that GPS position is last known or current GPS position.	“C” - GPS posn specified in 5 is the current position. “L” - GPS posn specified in 5 is the last know position i.e. NOT current.
<7.cams_conn>	List of cameras connected.	“C” - Colour camera is connected. “B” - Black and white camera is connected. “N” - Camera is NOT connected (i.e. disconnected).
<8.curr_ts>	Snapshot of current timestamp.	“Current timestamp” - Timestamp.
<9.last_rec_file_ts>	Timestamp of last recorded file.	“Last file timestamp” - Timestamp. “NO RECORDINGS” - There are no recordings on disk.
<10.led_status>	Service/Fail/Record LED status.	“R” - Record LED is ON. “S” - Service LED is ON.
<11.log_ts>	Timestamp of the last log entry.	“Log timestamp” - timestamp. “” - May be blank if no log.
<12.log_mode>	Log entry mode.	“Mode text” - Mode text. “NO MODE” - No mode text available. “” - May be blank if no log.
<13.log_code>	Log entry code.	“Code text” - Mode text. “NO CODE” - No code text available. “” - May be blank if no log.

<14.log_desc>	Log entry description.	"Desc text" - description text. "NO LOG" - No logs available.
---------------	------------------------	--

DETAILED DESCRIPTIONS

A description of the expected content for each heading in the message follows:

<1. type>

Description: The type of message or the reason the message has been sent (the fleet mgmt may wish to know if it is the daily message or one they have just requested).

Content:

"0"	– SMS POWER-UP
"1"	– SMS SEND DAILY
"2"	– SMS SEND NOW
"3"	– SMS SEND NOW (via incoming SMS).

<2.serial_num>

Description: The serial number of the V400 unit.

Content:

Serial num	– The V400 6-digit serial number.
'_'	– Not known or not available.

<3.veh_id>

Description: Camera 1 optional text (OTHER>CAMERA OPTIONS).

This is selected for inclusion in the message via the Health over SMS

hidden menu.

Content:

Camera1 text	– Camera1 text, up to 12 chars.
'_'	– No optional camera 1 text specified or not included in the menu.

<4.veh_id1>

Description: Filename optional text (OTHER>FILE SYSTEM).

This is selected for inclusion in the message via the Health over SMS hidden menu.

Content:

Filename text	– Filename text, up to 12 chars.
'_'	– No optional filename text specified or not included in the menu.

<5.gps_pos>

Description: The current or last known GPS posn (specified as longitude then latitude in degrees and minutes).

Content:

"ddmmm.mmmmX dddmm.mmmmX"	– GPS posn
'_'	– No GPS data available.

<6.last_curr>

Description: An indication if the GPS posn is the current posn or last known.

Content:

- "C" – GPS posn specified in 5 is the current posn.
- "L" – GPS posn specified in 5 is the last know posn (i.e. NOT current).

<7.cams_conn>

Description: Camera status.

Content:

- "C" – Colour camera is connected.
- "B" – Black and white camera is connected.
- "N" – Camera is NOT connected (i.e. disconnected)

Cameras are listed as 1234 etc, e.g. CCBN is a 4 camera system, where cam1,2=colour, cam3=B&W, cam4 disconnected.

Camera systems are either 4 or 16.

<8.curr_ts>

Description: Current V400 system timestamp.

Format is "hhmmss ddmmyy" or "hhmmss mmddy" depending on menu setting (OTHER>TIME AND DATE mode option).

Note that there are no separator characters in the time and date strings due to message size limitations.

Content:

Current timestamp - Timestamp.

<9.last_rec_file_ts>

Description: The timestamp of the last recorded file (i.e. newest file).

Format is "hhmmss ddmmyy" or "hhmmss mmddy" depending on menu setting (OTHER>TIME AND DATE mode option).

Note that there are no separator characters in the time and date strings due to message size limitations.

Content:

Last file timestamp - Timestamp.

'-' - There are no recordings on disk.

<10.led_status>

Description: V400 front panel LED status.

Contents:

- "R" - Record LED is ON.
- "S" - Service LED is ON.
- "F" - Fail LED is ON.
- '-' - No LEDs are on (with exception of the power LED).

The information under the remaining headings pertains to the last service or fail log (newest log).

If the Service and/or Fail LED are reported as ON under the previous heading, then the last service or fail log information is included in the message.

If no service or fail logs are available (e.g. if a service log reset has been performed), then no log information will be available.

<11.log_ts>

Description: The timestamp of the last service log.

Format is “hhmmss ddmmyy” or “hhmmss mmddy” depending on menu setting (OTHER>TIME AND DATE mode option).

Note that there are no separator characters in the time and date strings due to message size limitations.

Contents:

Log timestamp – timestamp

“_” – May be blank if no log.

<12.log_mode>

Description: Service log mode, e.g. Service, Failure.

Contents:

Mode text – Mode text.

“_” – No mode available or no log available.

<13.log_code>

Description: Service log code relating to mode.

Contents:

Code text – Mode text.

“_” – No code available or no log available

<14.log_desc>

Description: Reason for service log.

Note: Due to message length constraints, this information may be partial or missing.

Desc text – Log description text.

“_” – No logs available.

SPECIAL NOTES

The timestamp format is either “hhmmss ddmmyy” or “hhmmss mmddyy” depending on the mode setting on the unit. Note the lack of ‘:’ and ‘/’ separators (the default setting is to include the separators).

If the message is too big for a single SMS, then the message is cut short starting with the Service Log entry description (i.e. the last entry). The service log info must be appended to the end as it is the only variable that has a changing length (with the exception of veh_id, veh_id1). All other variables (when available) are a fixed length. If they are not available (e.g. NO GPS DATA), then the info string is usually less chars than the real data, with the exception of NO LEDS for led_status.

Final page of Appendices
